

Philadelphia Art Commission
 One Parkway Building
 1515 Arch St., 13th Floor
 Philadelphia, PA 19102
artcommission@phila.gov



Philadelphia
Art Commission
 CITY OF PHILADELPHIA

Art Commission Signage Review Cover Letter

Date: 5/7/26

Name of Business or Entity (to which the sign is accessory): Zac's Hala!

Sign Location (Address): 104 S 18th St. On Public Property? Yes No

Is this location in an Overlay Zoning District requiring Art Commission signage review?

Yes (specify): _____ No Unsure

Total Number of Signs: 1 Type(s) of Signs (check all that apply below):

- Wall Projecting/Blade Marquee Awning or Canopy Building ID (above 2nd story)
 Window Other: _____

Sign Details (if more than four (4), include details in *Additional Description* box below):

#	Sign Type	Dimensions	Mounting Height	Material(s)	Illumination (check if so)
1	wall	46" h x 98" w	15'	trim, coil, acrylic, vinyl	<input checked="" type="checkbox"/>
2					<input type="checkbox"/>
3					<input type="checkbox"/>
4					<input type="checkbox"/>

Additional Description (optional) (details, background/context, purpose/need, specific requests, etc.):

Remove existing sign. Manufacture and install (1) set of internally illuminated channel letters on a raceway. We are using the existing electrical line. No changing in electric.

Primary Contact for Art Commission

Communications:

Name: Dmitry Kipervas
 Company: All State Sign
 Address: _____
 Email: _____
 Phone: _____

Contact to Receive Art Commission

Decision (if different):

Name: _____
 Company: _____
 Address: _____
 Email: _____
 Phone: _____



SCOPE OF WORK

1. Remove the existing sign.
2. Manufacture and install internally illuminated Channel Letters on a raceway:
 - black trim;
 - black coil;
 - white face with vinyl.

NOTE: DESIGN WIND - 115MPH (IBC - 2018)
TOTAL SIGN WEIGHT: 145 lbs

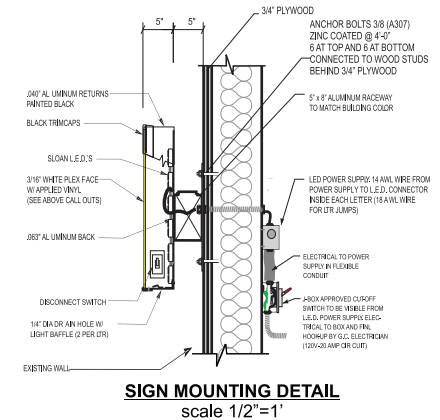

SITE PLAN

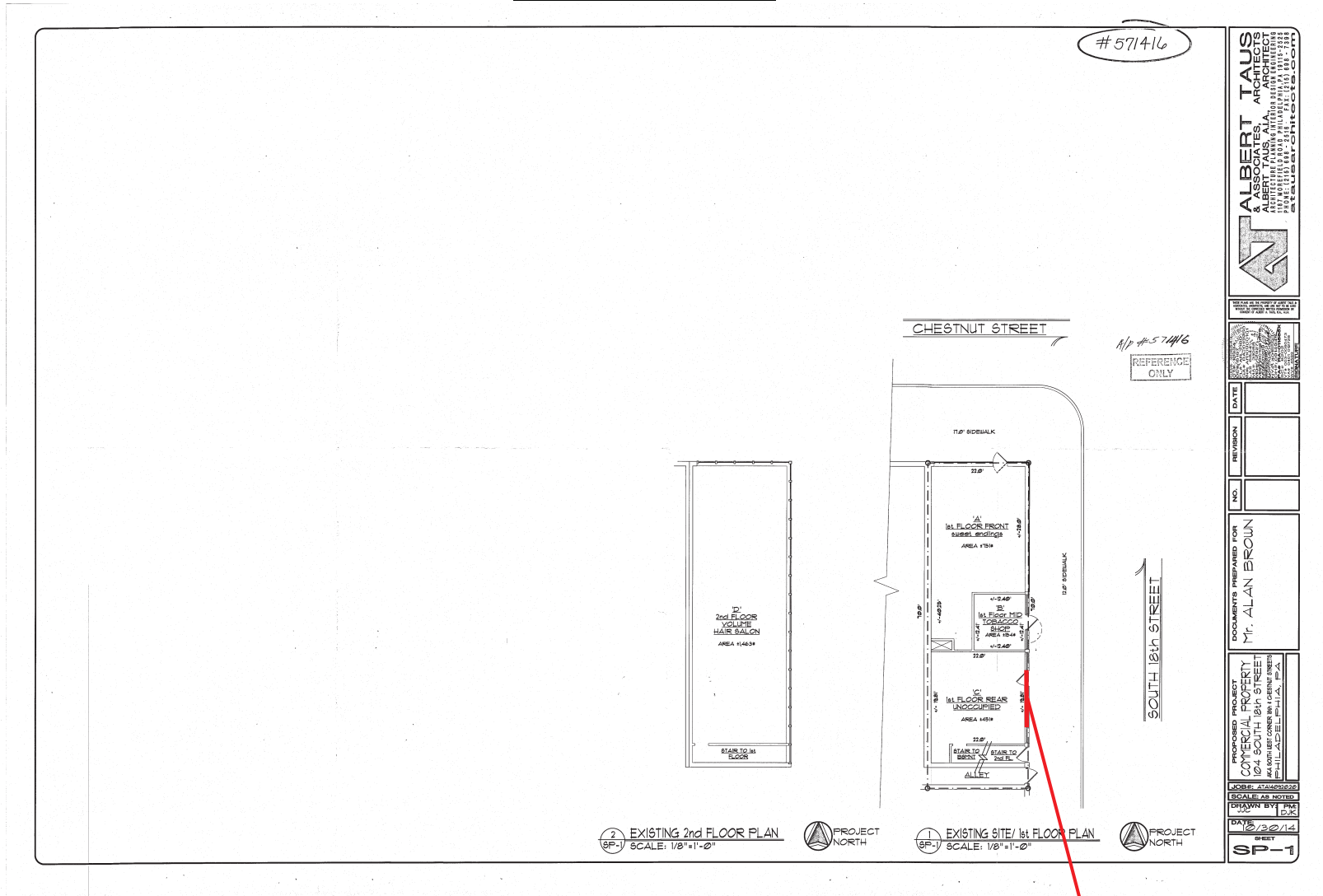

PROPOSED SIGN

ALBERT TAUS & ASSOCIATES, ARCHITECTS
ALBERT TAUS, AIA, ARCHITECT
1115 W. CHESTNUT STREET, PHILADELPHIA, PA 19107
TEL: 215-591-0100 FAX: 215-591-0101
WWW.ALBERTTAUS.COM

DATE

REVISION

NO.

DOCUMENTS PREPARED FOR
Mr. ALAN BROWN

PREPARED FOR
COMMERCIAL PROPERTY
1804 SOUTH 18th STREET
PHILADELPHIA, PA

NO. 571416

SCALE AS NOTED

DRAWN BY
PK

DATE
12/2/14

SHEET
SP-1