

ADDRESS: 6363 OVERBROOK AVE

Proposal: Construct deck on front porch roof

Review: Final Approval

Owner: Steven A. Cunningham

Applicant: Alvin Holm, Alvin Holm AIA Architects

History: 1903; Hoar/McCahan House; Horace Trumbauer, architect; 1920, alterations, W.F.

Price

Individual Designation: None

District Designation: Overbrook Farms Historic District, Contributing 11/8/2019

Staff Contact: Josh Schroeder, joshua.schroeder@phila.gov

BACKGROUND:

This application proposes to construct a deck on the front porch of the dwelling at 6363 Overbrook Avenue. The front porch was open when the home was originally constructed but is was later enclosed. The proposed deck would cover the entire roof of the front porch as well as the car park to the side. The proposed deck would include vinyl railings and a new semi-circular platform supported by four new columns extending over the front steps to the porch. An exterior steel spiral staircase to access the roof from the ground would be included on the side opposite the car park.

Construction of the roof deck began in the fall of 2025 without permits or review by the Historical Commission. The Department of Licenses and Inspections issued a stop work order and violation in January 2026. Images show that a platform over the porch roof, posts for the railing, and bases for the columns have already been constructed. The two outermost second-floor windows on the front façade have been removed, the openings altered for doors, and new doors and exterior light fixtures installed. The submitted plans show the new second-floor doors as existing, but this change was made as part of the construction of the deck.

SCOPE OF WORK: Construct deck on front porch roof, alter front facade, and add spiral staircase.

STANDARDS FOR REVIEW:

The Secretary of the Interior's Standards for the Treatment of Historic Properties and Guidelines include:

- *Standard 2: The historic character of a property will be retained and preserved. The removal of distinctive materials or alterations of features, spaces and spatial relationships that characterize a property will be avoided.*
- *Standard 9: New additions, exterior alterations, or related new construction will not destroy historic materials, features, and spatial relationships that characterize the property. The new work will be differentiated from the old and will be compatible with the historic materials, features, size, scale and proportion, and massing to protect the integrity of the property and its environment.*
 - The proposed alterations substantially change the front façade's appearance. The house originally featured an open front porch. An upper-level deck with a more ornate front entrance, steel spiral staircase, and removal of second-story windows is a further departure from the house's original and historic appearance. Therefore, the application fails to satisfy Standards 2 and 9.

STAFF RECOMMENDATION: Denial, pursuant to Standards 2 and 9.



Image 1: 6363 Overbrook Ave, showing appearance before work was started. Cyclomedia, December 2022.



Image 2: 6363 Overbrook Ave, showing extent of work completed, on 3/30/2026.



Image 3: 6363 Overbrook Ave, showing extent of work completed, on 3/30/2026.



Image 4: 6363 Overbrook Ave, showing extent of work completed, on 3/30/2026.



2026
Permit Application RP-~~2006~~-002457

From Alvin Holm <alvinholmaia@aol.com>
Date Mon 4/6/2026 1:11 PM
To Joshua Schroeder <Joshua.Schroeder@phila.gov>
Cc scunnin649@aol.com <scunnin649@aol.com>

📎 4 attachments (2 MB)

Overbrook A-1.pdf; Overbrook A-2.pdf; Overbrook A-3.pdf; Overbrook C-1 and C-2.pdf;

External Email Notice. This email comes from outside of City government. Do not click on links or open attachments unless you recognize the sender.

Roof Deck Construction at ~~6262~~ Overbrook Avenue
6363

Dear Mr. Schroeder,

As we have discussed earlier I am writing today to supplement Steven Cunningham's Application for a Permit to build a roof deck on the existing front porch of his home at ~~6262 Overbrook Avenue~~ 6363 Overbrook Ave which his father had purchased in 1958. His personal reasons for creating the deck are beautifully described in his own words in his letter to you today (attached below). In support of his project I should note that his stated idea came from seeing the many other roof decks all over his own neighborhood, and in discussions with me he listed thirteen specific examples nearby. (see below)

My own professional enthusiasm has always been for design in the very broad Classical tradition, so I have always admired the many examples in the Overbrook Farms community. So when I was asked to provide drawings for this project I was very pleased. I believe the proposal is completely consistent with the architecture of the surrounding area, and it does not diminish the integrity of the handsome existing building. I have attached below an early photograph of the home as it was designed by the notable architect Horace Trumbauer and built in 1925. Another attached photograph taken in recent years illustrates some radical renovations that significantly alter (and enhance) the original appearance and the interior spaces as well. First you may notice on the side wall the two octagonal bay extensions on the first and second floors. And then you may note how the original open front

porch is now fully windowed to create additional interior areas.

Compared to those earlier radical alterations the current proposed addition of a terrace to the existing porch roof does very little to modify the general appearance at all. And it is completely in character with the buildings original design as well as with the entire historic neighborhood.

I am completely open to any additional questions. For my credentials see <http://www.alvinholm.com>. Please let me know how I can provide any further assistance.

Sincerely,

Alvin Holm

Alvin Holm AIA Architects
2014 Sansom St. Philadelphia PA 19103
215-963-0747 office, 610-547-1301 cell

Attachments: A-1 Current Appearance 2026
C-1 Owners Own Explanation
C-2 Owners list of Roof Decks
A-2 Octagonal Additions (date unknown)
A-3 Original Appearance 1925

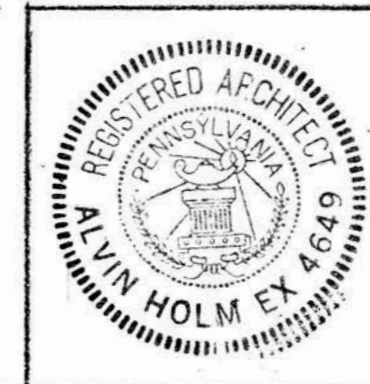
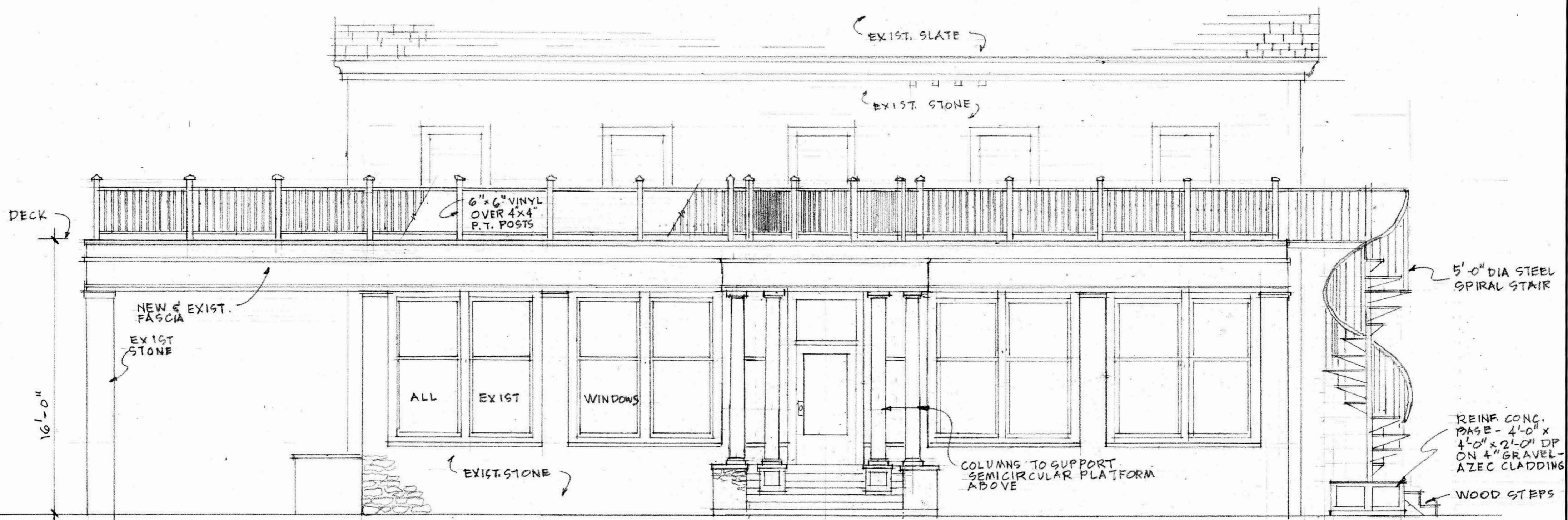
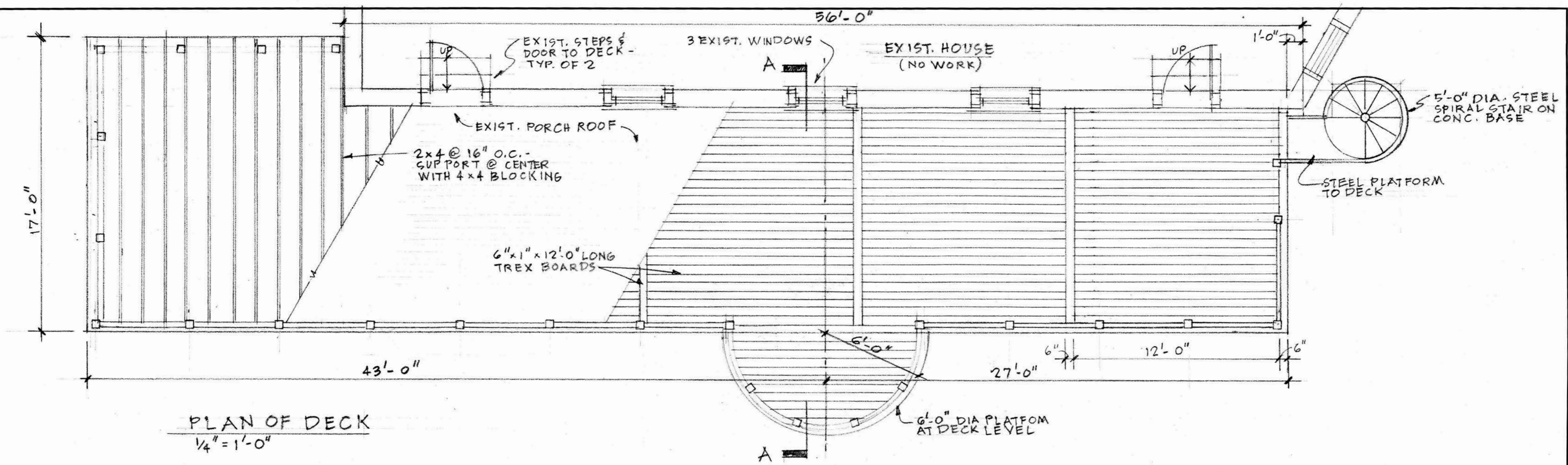

PROPOSED ROOF DECK AT 6363 OVERBROOK AVE - PHILADELPHIA PA - 19151		
SCALE: 1/4" = 1'-0"	APPROVED BY:	DRAWN BY JMD
DATE: 3-20-26		REVISED
ALVIN HOLMAIA ARCHITECTS 2014 GANSON ST - PHILADELPHIA PA - 19103		
DECK PLAN & ELEVATION		DRAWING NUMBER 1 OF 2



PLAN OF FRONT ENTRANCE
1/2" = 1'-0"

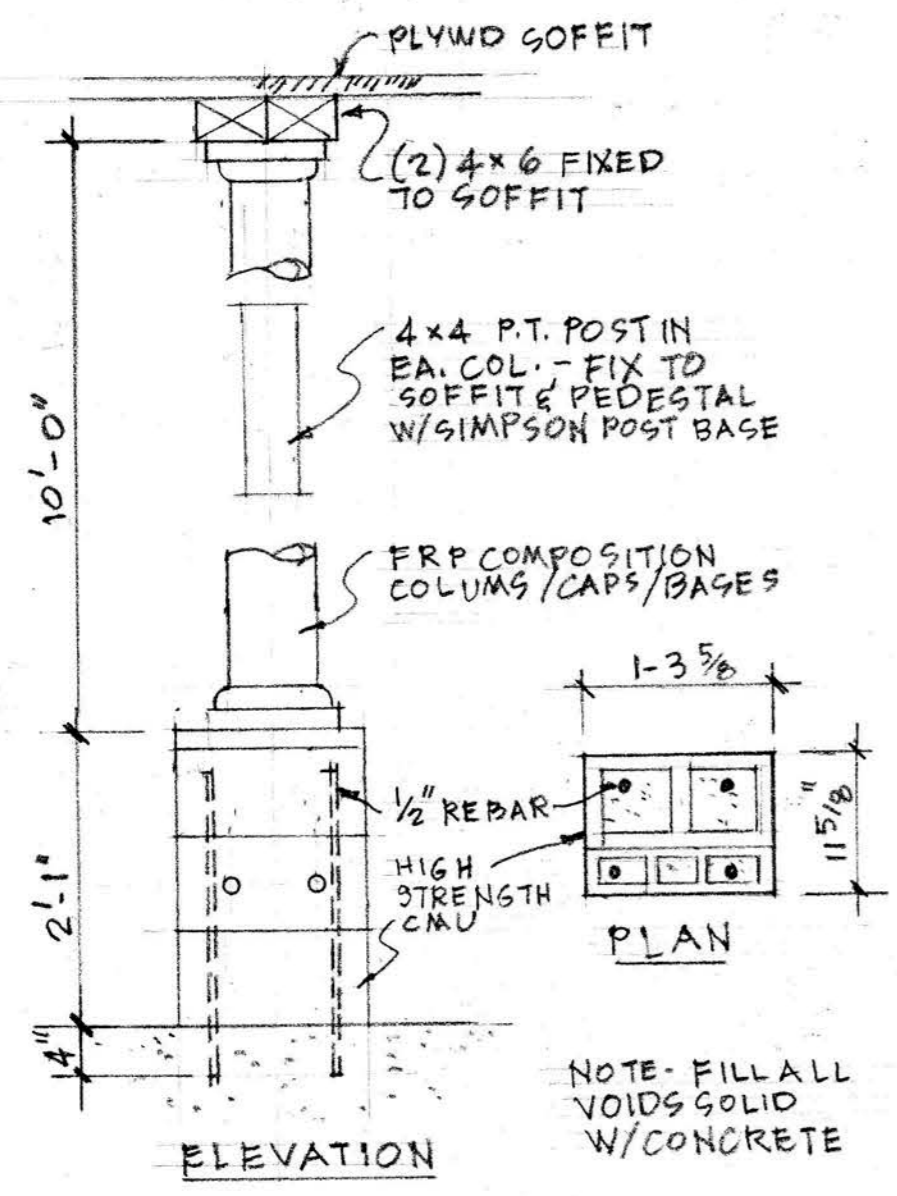

COLUMN & PEDESTAL DETAILS
3/4" = 1'-0"

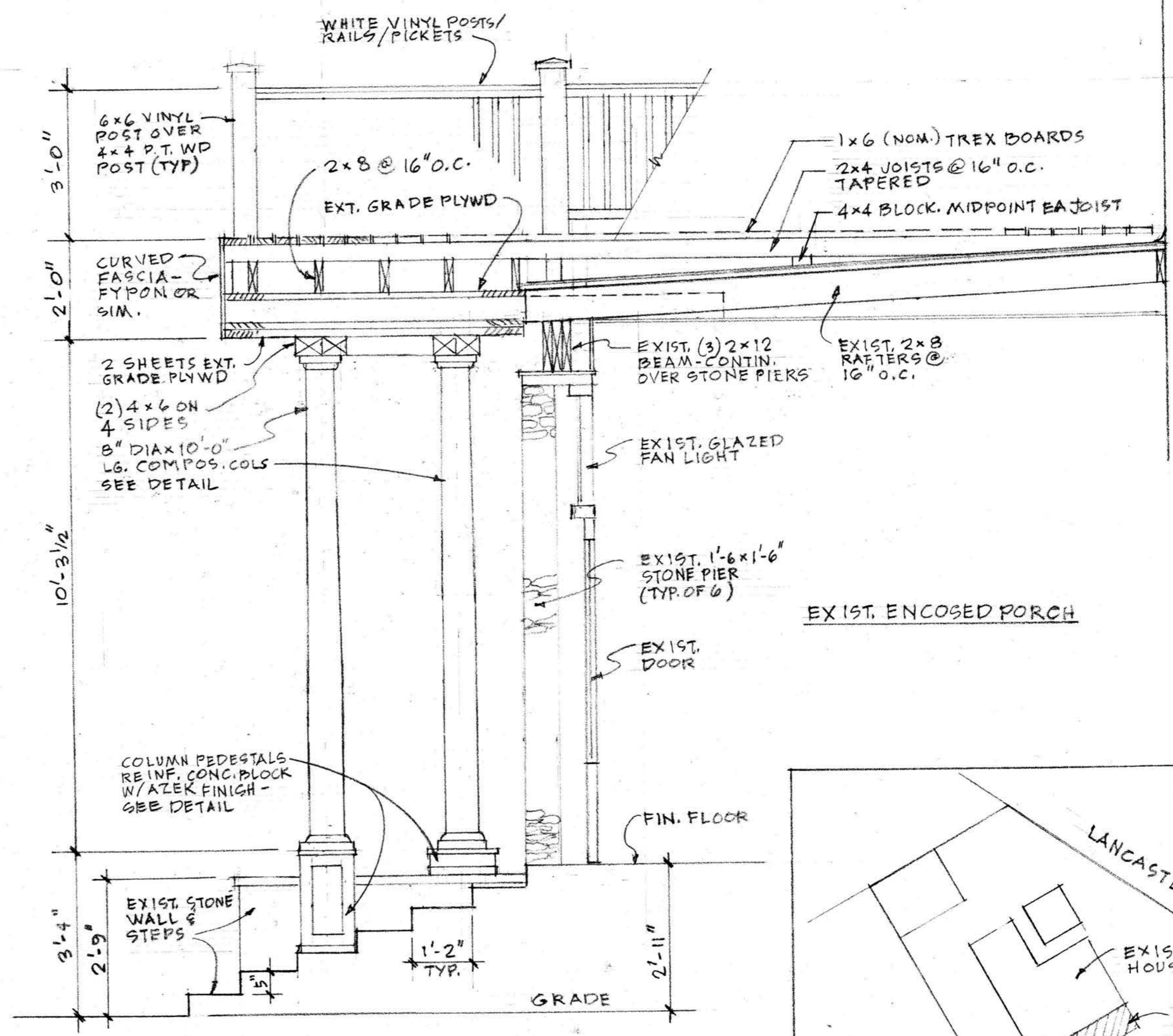

SECTION A-A
1/2" = 1'-0"

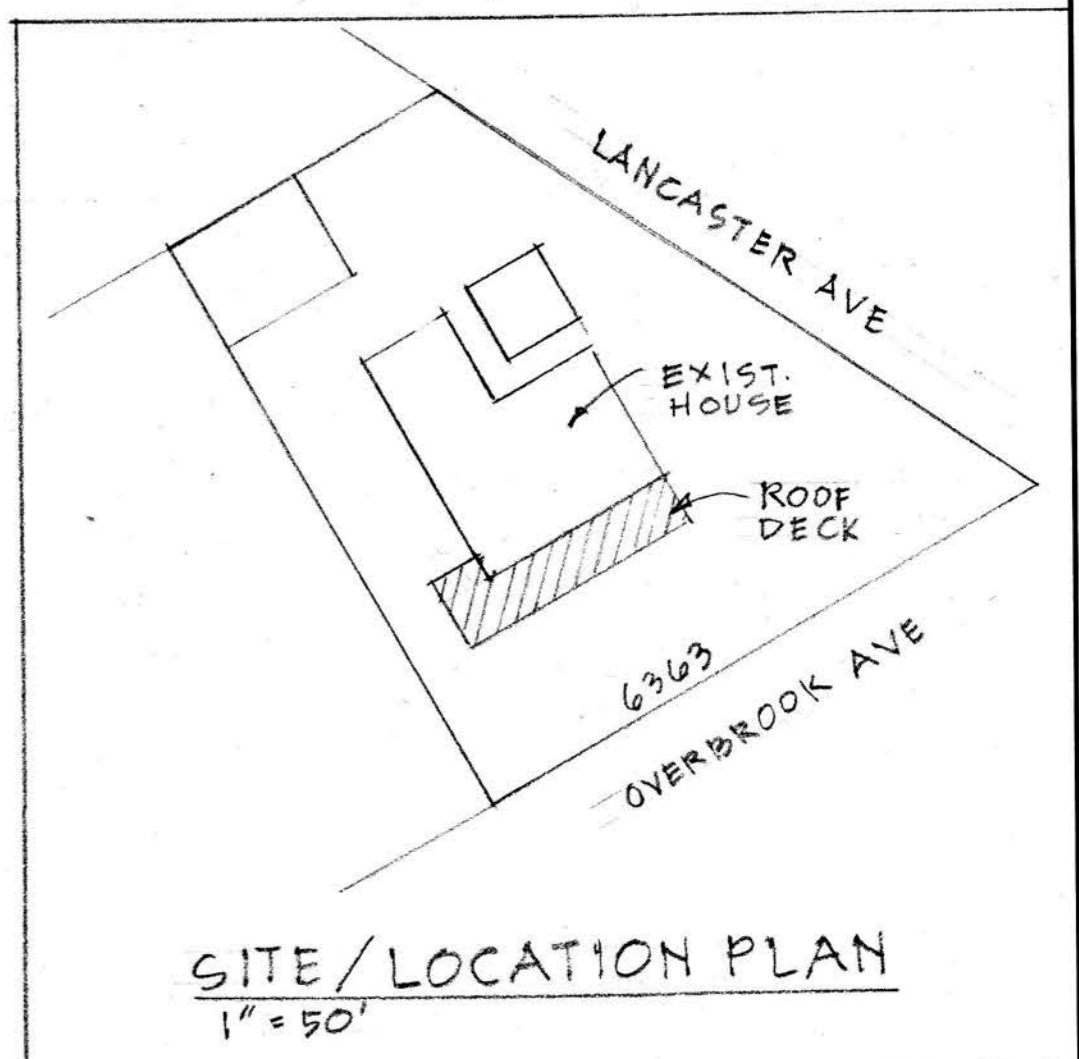

- NOTES**
1. THE WORK SHALL CONFORM TO ALL APPLICABLE FEDERAL, STATE AND LOCAL BLDG. CODES
 2. ALL NEW LUMBER TO BE PRESSURE-TREATED
 3. VINYL RAILING SYSTEM MUST WITHSTAND A 200 LB CONCENTRATED LOAD TEST
 4. COLUMNS TO BE TURNCRRAFT POLY-CLASSIC FRP HOLLOW - 8" BOTTOM DIA, 7" TOP DIA. WITH LOAD CAPACITY OF 10,000 LBS



PROPOSED ROOF DECK AT 6363 OVERBROOK AVE - PHILADELPHIA, PA 19151		
SCALE: AS NOTED	APPROVED BY:	DRAWN BY JMD
DATE: 3-20-26		REVISED
ALVIN HOLM AIA ARCHITECTS 2014 GANSON ST. - PHILADELPHIA PA 19103		
SECTION & DETAILS		DRAWING NUMBER 2 OF 2



A-1

DATE: 4.4.2026
SCALE:
DRAWN:
REVISION:

CURRENT APPEARANCE 2026

Contractor shall verify dimensions and existing conditions before proceeding with work.

6363 OVERBROOK AVE

ALVIN HOLM, A.I.A., ARCHITECTS
2014 SANSOM STREET—PHILADELPHIA, PA 19103





OVERBROOK, PA. - RESIDENCE OF MRS. D. J. HOAR.

R-2

DATE: A. 4. 20 26
SCALE:
DRAWN: all
REVISION:

ORIGINAL APPEARANCE 1925

Contractor shall verify dimensions and existing conditions before proceeding with work.

16965 OVERBROOK AVE

ALVIN HOLM, A.I.A., ARCHITECTS
2014 SANSOM STREET—PHILADELPHIA, PA 19103

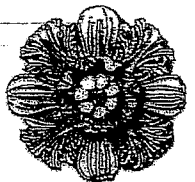



A-3

DATE: 4.14.2026

SCALE:

DRAWN: KPH

REVISION:

OCTAGONAL ADDITIONS

Contractor shall verify dimensions and existing conditions before proceeding with work.

4363 OVERBROOK AVE

ALVIN HOLM, A.I.A., ARCHITECTS
2014 SANSOM STREET—PHILADELPHIA, PA 19103

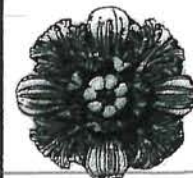

C-2

Neighbors with second story roof decks in front

From: Steven Cunningham (scunnin649@aol.com)

To: conorcorcoran@yahoo.com; alvinholmaia@aol.com

Date: Wednesday, February 25, 2026 at 12:23 PM EST

Here are just a few of my neighbors with 2nd story roof top decks on the front of the house

- 1.) 7100 Sherwood
- 2.) 6491 Drexel
- 3.) 6417 Church
- 4.) 6399 Drexel
- 5.) 6391 Drexel
- 6.) 6346 woodbine
- 7.) 6441 woodbine
- 8.) 6457 woodbine
- 9.) 6490 woodbine
- 10.) 6408 overbrook
- 11.) 6301 Sherwood
- 12.) 6339 Sherwood
- 13.) 6400 woodbine

[Sent from AOL on Android](#)

C-1

Re: Permit Review Complete for RP-2026-002457

From: cnotemusicphilly (cnotemusicphilly@aol.com)

To: joshua.schroeder@phila.gov

Cc: alvinholmaia@aol.com

Date: Friday, April 3, 2026 at 01:06 PM EDT

Hello Joshua Schroeder,
 I am Steven Cunningham, the owner of the property at 6363 Overbrook ave
 Phila Pa 19151. I am responsible for this project . My email is:cnotemusicphilly@aol.com
 My cell phone is 610-304-3444
 I live here and occupy the property at
 6363 Overbrook ave
 Phila pa 19151

The reason I am undertaking this project is to be able to enjoy a beautiful raised deck, have morning coffee, eat meals read books, play my guitar, and entertain guests. My family has been here, and active in Overbrook farms community since 1958 when they bought this house. I purchased the house from my Mother in 2002. I got the idea for a roof deck after seeing many other roof decks on my neighbor's homes. I think they look beautiful, and add style ,elegance and function to each one. I will ,along with Alvin Holm be sure to keep this project in line with the architectural intent of the original design. This project's design features will match the existing interior, and exterior of my home. My home has been the featured home, and host to the yearly Spring Overbrook Farms house tour many times. I would like to do that again, to welcome guests and feature the roof deck this time on the tour. I can provide pictures or addresses of the other roof decks if you need them. My neighbors are excited to see this project come to completion, and have offered to write letters of recommendation if needed. I believe my architect Alvin Holm AIA will be supplying you with the pictures from the street that you asked for. Please let me know if there's anything else you need from me and I will be happy to get it to you. I believe Mr Holm's drawings answered a good deal of your questions as well. I greatly appreciate your consideration!

Sincerely,
Steven Cunningham

C-1+C-2

DATE: 4-4-26
 SCALE:
 DRAWN:
 REVISION:

C-1 OWNERS OWN EXPLANATION

Contractor shall verify dimensions and existing conditions before proceeding with work.

C-2 OWNERS LIST OF ROOF DECKS

6363 OVERBROOK AVE

ALVIN HOLM, A.I.A., ARCHITECTS
 2014 SANSOM STREET—PHILADELPHIA, PA 19108

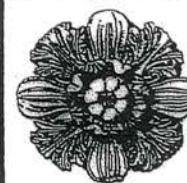

Violation Notice and Order to Correct

L&I File Number: CF-2026-000336

RESPONSIBLE PARTY STEVE A CUNNINGHAM 6363 Overbrook Ave Philadelphia, Pennsylvania 19151	V1 	DISTRICT OFFICE Construction Complaint Unit 7522 Castor Ave Philadelphia, PA 19111 215-685-0583 LIConstruction.complaints@phila.gov
--	---	---

PROPERTY IN VIOLATION 6363 OVERBROOK AVE, Philadelphia, PA 19151-2509	DATE OF NOTICE 01/21/2026
---	-------------------------------------

On 01/06/2026 the Department of Licenses and Inspections inspected/investigated the property in violation and found the following condition(s) or activity which violate the Philadelphia Code. Based on these the property is deemed:

IN VIOLATION

The property will remain in this status until all the violations below are corrected and the Department of Licenses and Inspections has verified the corrective action. You are the person responsible for the correction of these violations.

Any permit or license obtained to comply a violation of working without or in excess of a permit or a license will result in an additional inspection fee equal to the cost of the permit or license. (Phila. Code § A-901.13)

YOU ARE ORDERED TO MAKE THE NECESSARY REPAIRS AND/OR TAKE THE NECESSARY ACTION(S) TO CORRECT THE CITED CONDITIONS PRIOR TO 02/23/2026

VIOLATIONS

PHILA. CODE §	FINE AMOUNT	SCAN QR CODE FOR HOW TO RESOLVE
A-301.1/3	\$300.00	
PHILA. CODE LANGUAGE A building permit is required for altering, modifying, repairing or improving the exterior portion of the structure.		
CONDITION IN VIOLATION Second-floor deck being installed without permits, engineer services, or historical approval.		
LOCATION Front exterior		

Violation Notice and Order to Correct

L&I File Number: CF-2026-000336

VIOLATIONS

PHILA. CODE §	FINE AMOUNT	SCAN QR CODE FOR HOW TO RESOLVE
A-203.2/1	\$300.00	
PHILA. CODE LANGUAGE A violation has been issued because the used materials, equipment and/or devices are not approved.		
CONDITION IN VIOLATION Second-floor deck being built without permits, engineer services, or historical approval.		
LOCATION Front exterior		

PHILA. CODE §	FINE AMOUNT	SCAN QR CODE FOR HOW TO RESOLVE
A-304.1/1	\$300.00	
PHILA. CODE LANGUAGE You are hereby ordered to retain a Pennsylvania-licensed professional engineer as the design professional in responsible charge, per Administrative Code Section A-304: <ul style="list-style-type: none"> •The engineer must immediately assess structural defects and submit findings with a corrective action timeline to the Department. •They must design and oversee the installation of temporary public way and property protections. •Develop a remediation plan detailing structural repairs, temporary shoring, and code-compliant construction details, and submit the plan with a building permit application to the Department. •Throughout the repair process, the engineer must conduct periodic structural observations and notify the Department of any immediate public safety threats. •Upon completion, they must submit a sealed statement confirming the structure is safe. •If oversight responsibilities are terminated by the owner, the engineer must inform the Department. 		
CONDITION IN VIOLATION Architectural/engineer services are required.		
LOCATION Front exterior		

✕ Violation Notice and Order to Correct

L&I File Number: CF-2026-000336



Failure to timely correct the violations listed above by or before the correction date listed above will result in the stated fine amount being imposed against you. The fines will be imposed on a per day basis for each violation that remains uncorrected AFTER the stated correction date. Phila. Code § A-601. If you timely correct each violation by the stated correction date, no fines will be due.

In addition to the fines listed above, failure to timely correct the violations will result in you being charged:

- Labor and material costs for any work performed by the City, such as a demolition; sealing of windows or doors; clearing of weeds, trash or debris; relocation expenses for removing occupants, costs associated with cease operations orders. Such costs are subject to an additional administrative fee of 21% (Phila. Code § A-503);
- An additional \$100 fee for repeat abatement work (Phila. Code § A-503.2); and
- Reinspection fees as follows: \$100 for the third inspection, \$200 for the fourth inspection, and \$350 for any additional inspections (Phila. Code § A-901.12.2).



YOU HAVE THE RIGHT TO APPEAL THIS NOTICE. YOUR APPEAL MUST BE FILED BY 02/20/2026.

IF YOU DO NOT TIMELY FILE AN APPEAL THEN YOU WAIVE YOUR RIGHT TO LATER CHALLENGE ANY PART OF THIS NOTICE. This includes waiving your right to argue: whether the violations existed, whether you were responsible to correct the violations, whether you had enough time to correct the violations, whether the City should have abated the violations, and whether the City can impose fines, fees, or costs against you.

For more information on filing an appeal and/or to obtain the approved form visit the appeals section of the Department of Licenses and Inspections website at www.phila.gov/li or the Boards Administration Unit, Concourse Municipal Services Building, 1401 J.F.K. Blvd., Philadelphia PA.

Appeals of the Technical Codes, such as the Zoning Code and/or Fire Code, need to be submitted to the appropriate Technical Appeal Board such as the Zoning Board of Adjustment and/or the Board of Safety and Fire Prevention. For additional information call 215-686-8686.

IF YOU HAVE ANY LEGAL QUESTIONS YOU SHOULD CONSULT WITH AN ATTORNEY.

If you do not have an attorney, you can contact the Philadelphia Bar Association Referral and Information Line at 215-238-6333 to have an attorney referred to you. You can also find a list of legal aid service providers at <http://palegalaid.net/legal-aid-providers-in-pa>.



The Philadelphia Code may be found online for free at www.phila.gov under "Open government."

If you have any questions regarding this notice or would like to schedule a re-inspection, please contact: NICHOLAS CLARK nicholas.clark@phila.gov or the district office noted above.

ATTENTION: This is an important notice! For information in your language, call 215-686-8686

ATENCIÓN: ¡Este es un aviso importante! Para recibir información en su idioma, llame al 215-686-8686

注意: 这是重要通知! 如果您需要以您的语言获得此信息, 请致电 215-686-8686

CHÚ Ý: Đây là thông báo quan trọng! Nếu bạn cần thư này bằng ngôn ngữ khác, vui lòng gọi 215-686-8686

주의: 중요 통지입니다! 이 서신을 귀하의 언어로 받고 싶으시면 215-686-8686번으로 전화하시기 바랍니다

پر کال کریں 215-686-8686 ترجمے کی خدمات کے لیے! یہ ایک ضروری اطلاع نامہ ہے: توجہ فرمائیے

ATTENTION: Cet avis est important! Si vous avez besoin de cet avis dans une autre langue, appelez le 215-686-8686