

# Memorandum



**To:** Beige Berryman, Director Art Commission  
**From:** Erin Kindt, Project Manager, DPP  
**Date:** June 28, 2023  
**Re:** Request for Art Commission Review

---

We respectfully request to be included on the Art Commission agenda for July 12th for Concept Approval for improvements to the Municipal Services Building's Thomas Paine Plaza.

A brief description of the project follows, and drawings will be submitted by the deadline on Wednesday July 5, 2023.

The Municipal Services Building ("MSB") and Thomas Paine Plaza were designed by Vincent Kling in 1962 during a transformative era in Philadelphia's city planning. The project consolidated public services for the growing city government into a 16-story building and raised plaza on a site next to City Hall that had long served as a public gathering space for concerts, speeches, and protests.

With a grand below-grade concourse and full basement of municipal offices, MSB's Paine Plaza sits above the street level and is accessed by several wide stairs and a ramp. Although the Plaza has served as a public square, backdrop for tourist photos and protest site, Paine Plaza suffers from its lack of visibility, seating, physical amenities and shade.

Building off Phase 1 waterproofing of the roof deck of the plaza, Phase 2 design improvements will reinvent Thomas Paine Plaza's role as a dynamic civic square for the present day. Reimagining the plaza as vibrant, accessible, and inviting space, the new design supports MSB employees and their constituents, while creating new spaces for citizens, civic organizations and visitors to visit and relax, or protest and be heard.

Managed by the Department of Public Property, the estimated project cost for Paine Plaza improvements is \$20M. Improvements include:

- New main entrance accessible ramp / sloped walk
- Tree shaded seating bosque
- Large plaza associated with Jacques Lipchitz' *Government of the People* that accommodates 1,000 people and includes an elevated platform, observation overlook, kiosk and shade canopy

- Small plaza that accommodates 500 people and includes an elevated platform/stage, seat walls and seating terrace
- New kiosk and shade canopy on the west side of the MSB Building
- New lighting / programmable themed lighting
- New pavers / paving
- New seating interventions and furniture
- Bicycle parking and access

Thank you for your attention. Please contact me directly if you need more information.

cc: Valerie Bergman, Deputy Commissioner, DPP: Valerie.Bergman@phila.gov  
Pedro Pinto, Project Director, DPP: Pedro.Pinto@Phila.gov  
Erin Kindt, Project Manager, DPP: Erin.Kindt@Phila.gov  
Marguerite Anglin, Public Art Director, OACCE: Marguerite.Anglin@phila.gov  
Karen Skafte, Ground Reconsidered: skafte@groundreconsidered.com  
Sarah Endriss, Ground Reconsidered: endriss@groundreconsidered.com





Department of

# Public Property

## THOMAS PAINE PLAZA

# Plaza Improvement Project



**Reconsidered**  
**Ground** Landscape Architecture



the  
lighting  
practice

**KSE**  
KS Engineers, P.C.

**IMEG**

**KH**  
KIMLEY-HORN

**HFA**  
HURLEY  
FRANKS  
ASSOCIATES



## RESIDENTIAL FABRIC

Mid-1800s: Project site was typical Philadelphia residential rowhouse fabric.

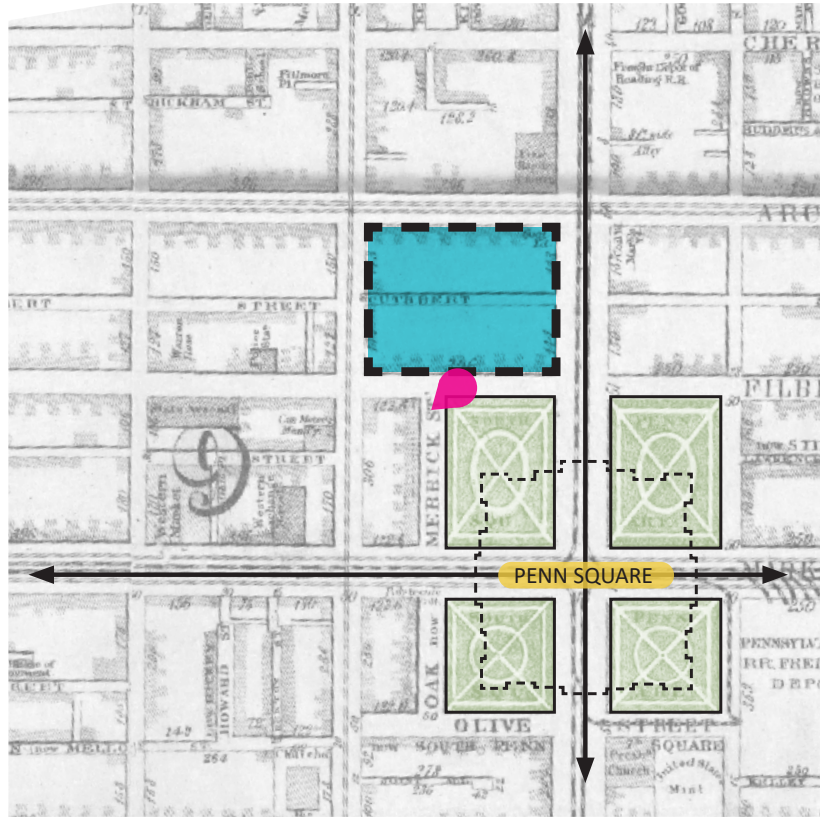

1862 Philadelphia Atlas



Image: Free Library - Historical Images

## REYBURN PLAZA

1917: The site is redeveloped as Reyburn Plaza in tandem with the Benjamin Franklin Parkway.

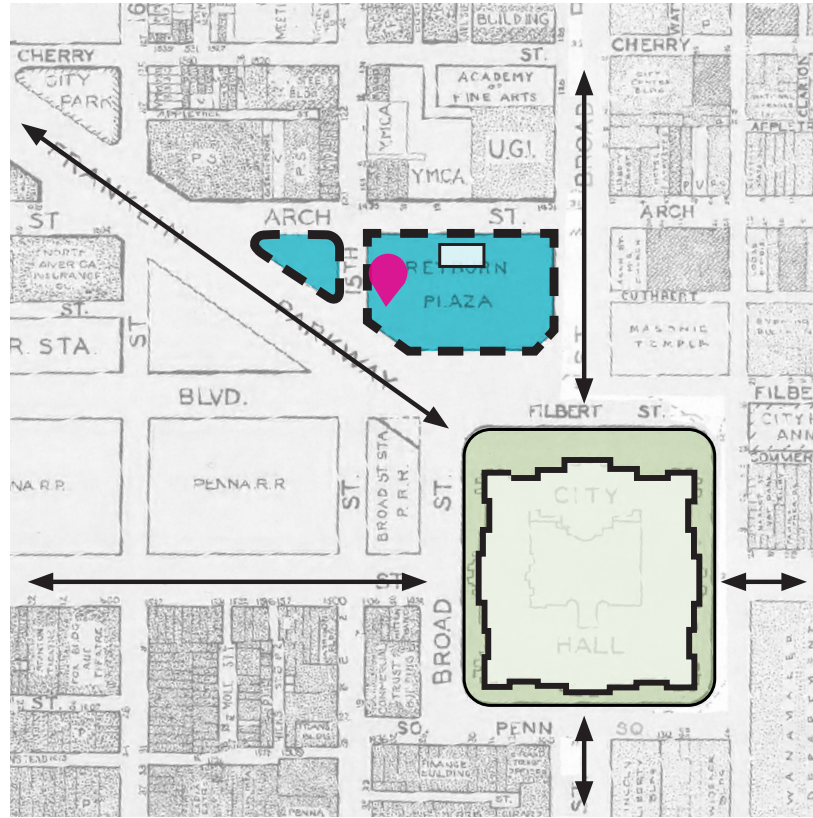

1942 WPA Land Use Map



Image: Temple University Archives

## MUNICIPAL SERVICES BUILDING

1962: The site is redesigned under Edmund Bacon's vision for downtown Philadelphia.

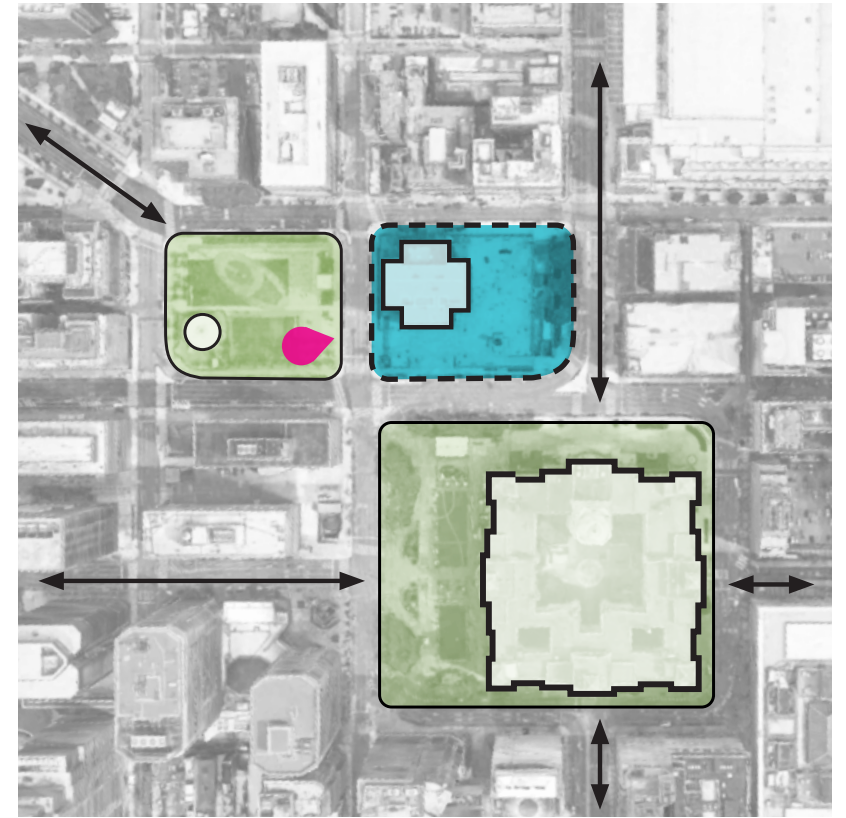

2023 Aerial Image



Image: Vincent Kling & Associates

## SITE HISTORY

THOMAS PAINE PLAZA  
Plaza Improvement Project



Ground Reconsidered  
Landscape Architecture



the lighting practice

KSE  
KS Engineers, P.C.

IMEG

KH  
KEAST & HOOD

HFA  
HURLEY FRANKS ASSOCIATES

# 1 ROOF WATERPROOFING PROJECT

Replace waterproofing membrane across extent of plaza

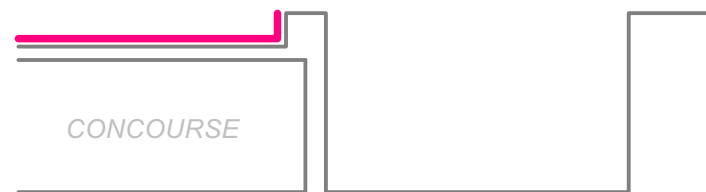

# 2 PLAZA IMPROVEMENTS

Make improvements to the design of the plaza, within existing perimeter walls and above structural deck

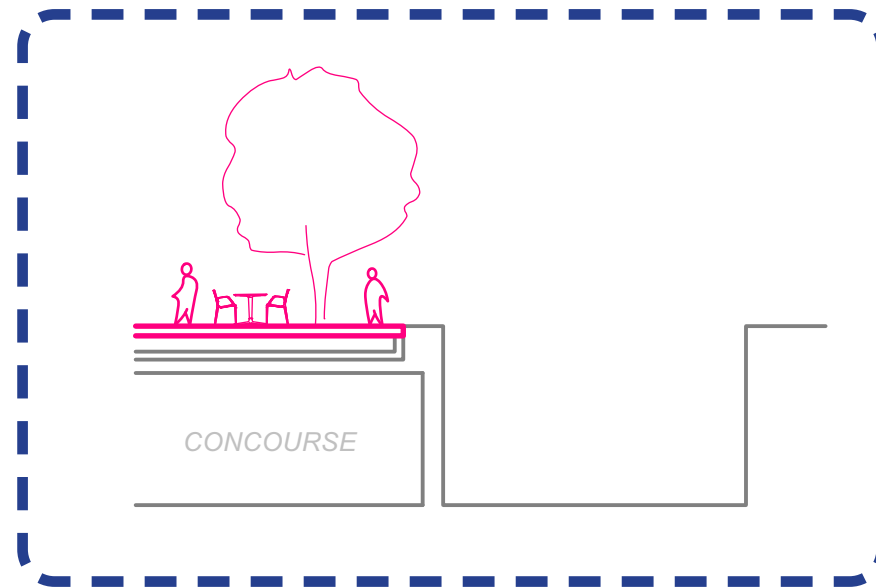

# 3 FUTURE PHASE

Infill the sunken plaza area and further connect to surrounding sidewalks per Philadelphia 2035 plan

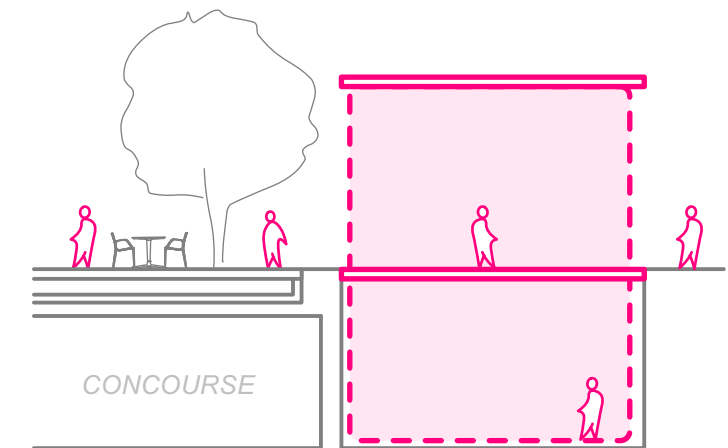

## PROJECT PHASES



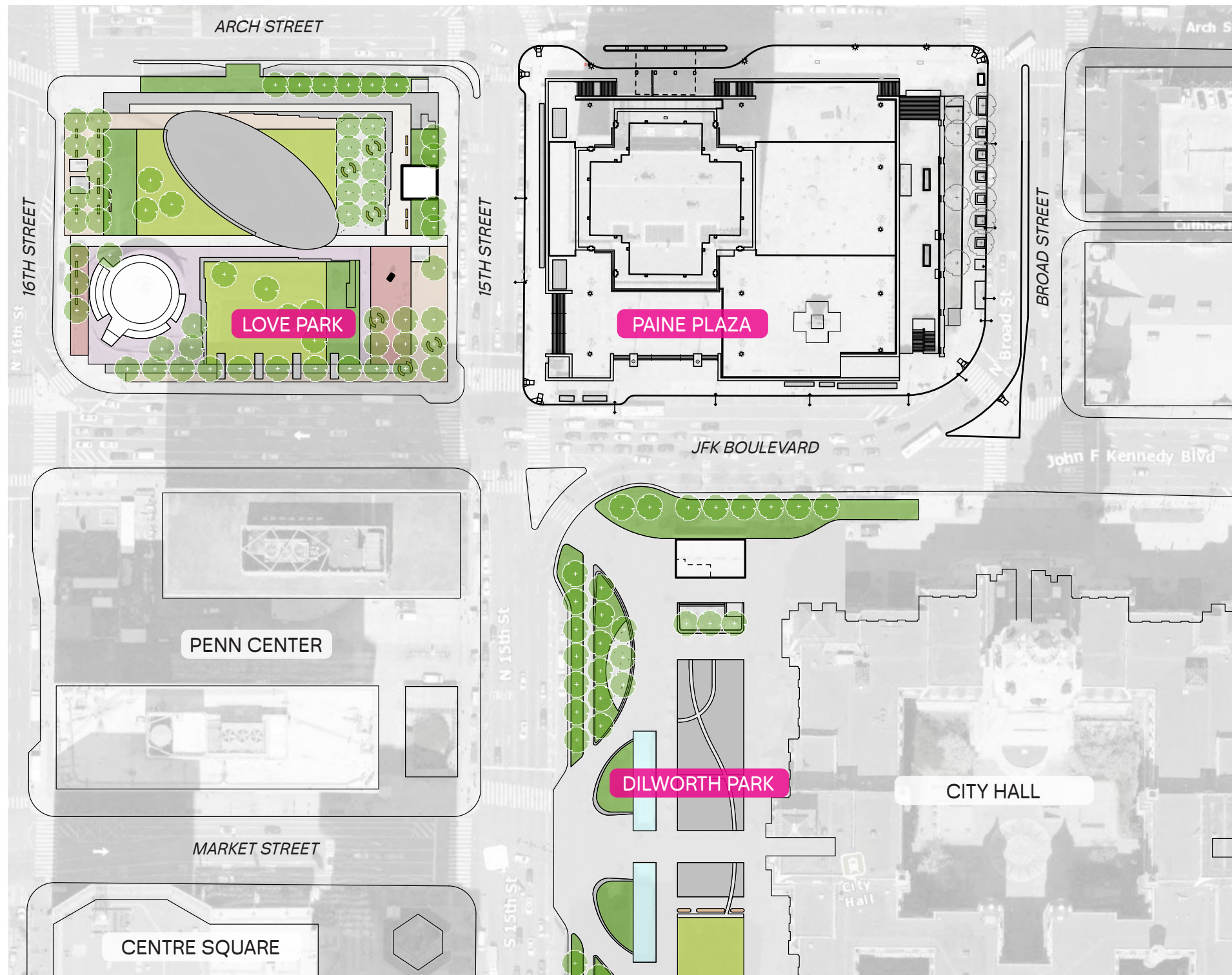

DILWORTH PARK

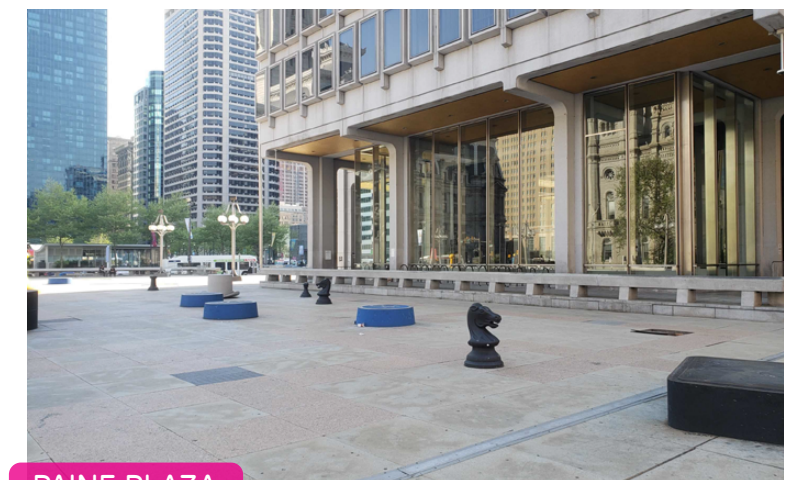

PAINE PLAZA



LOVE PARK

Image: PPR

**SITE CONTEXT**

THOMAS PAINE PLAZA  
Plaza Improvement Project





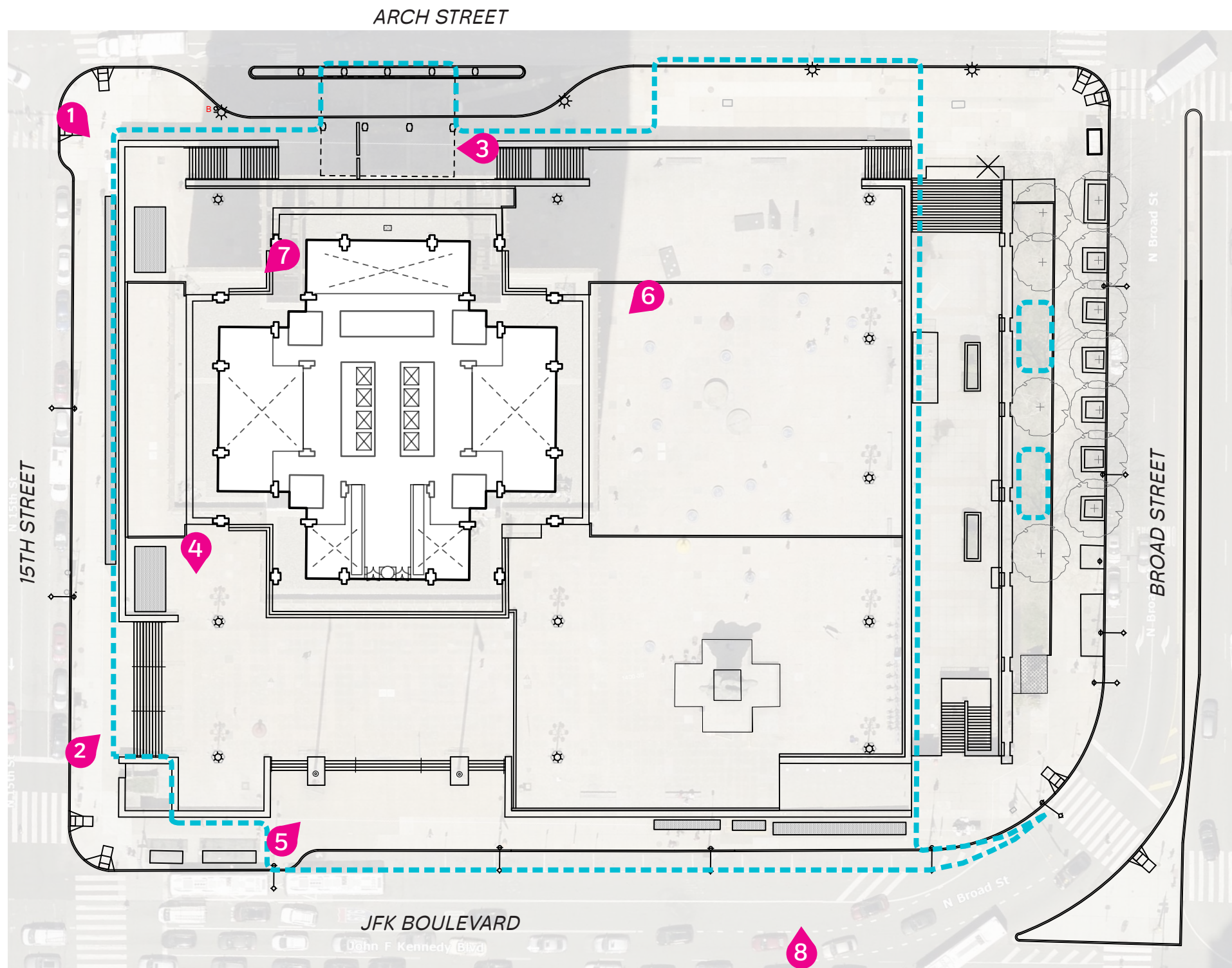

 PROJECT AREA

**EXISTING CONDITIONS**

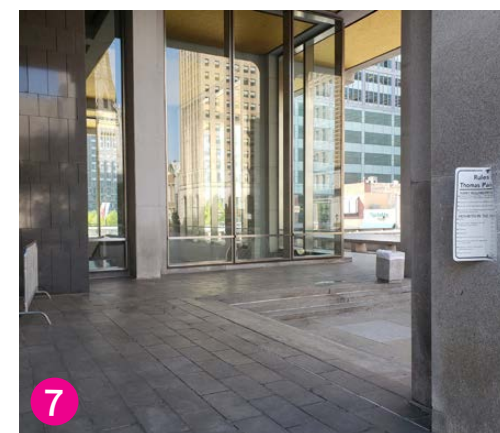
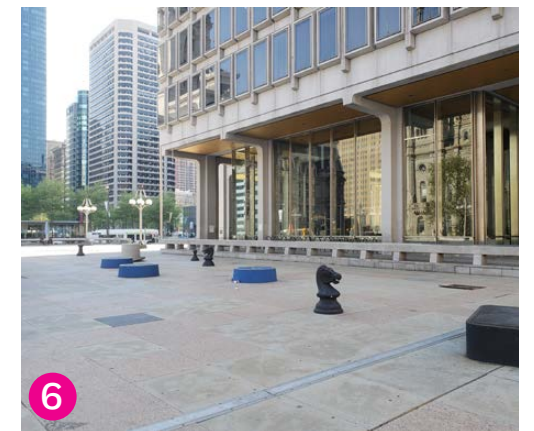
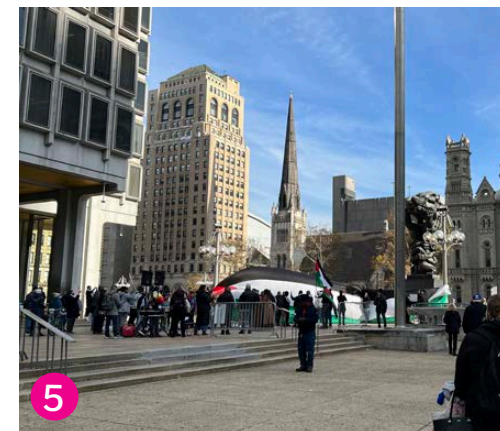
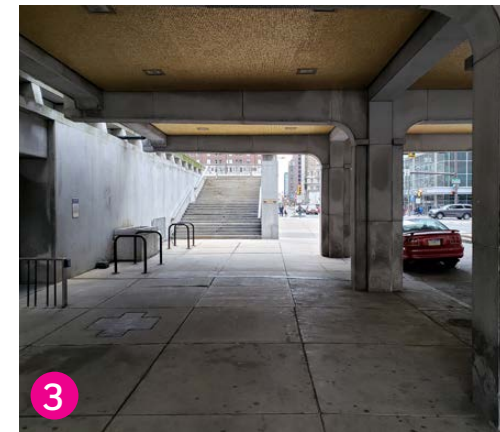
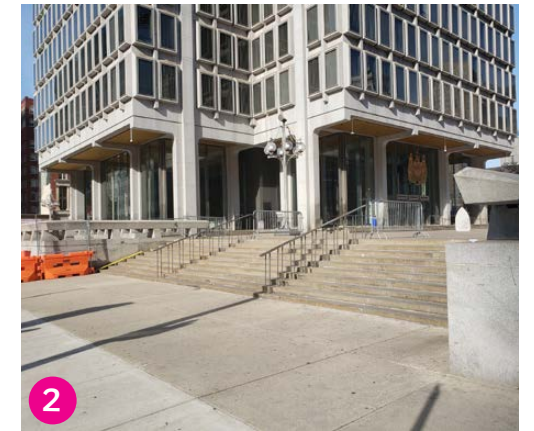







The plaza will remain a civic stage to host protests, demonstrations, and large events.



Photo © Conrad Brenner



Mural by Russel Craig. Photo © Kimberly Paynter

Based on survey feedback received, the top priorities for improving the plaza include:

**1 PLANTS AND GREEN SPACE**



**2 SAFE PLACES TO SIT, RELAX, AND GATHER**



**3 A VIBRANT, INVITING ATMOSPHERE**

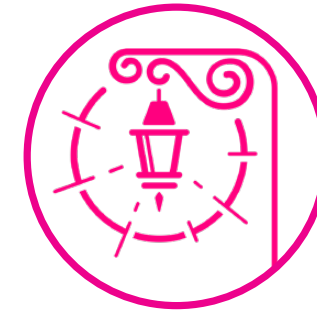

**4 IMPROVED ACCESSIBILITY**



Here's some of what we heard about each of these priorities:

"Please **ACTIVATE THIS SPACE!** Rotating garden treatment with seating areas for gathering like in front of City Hall that can be activated for a variety of uses."

"Create several **OUTDOOR SEATING AREAS** that are cleaned daily, especially in the mornings."

"Please remember it's intention to be a **PUBLIC SPACE TO BE ENJOYED BY ALL** who visit our city."

"A **WELCOMING ATMOSPHERE** where it's **ACCESSIBLE AND SAFE...**"

"It is important to make a space that is **WELCOMING TO ALL!**"

"Focus on **GREEN SPACE.**"

"It would be great to have some **GREENERY** to make the space **SHADY** on hot days."

"A **LOT OF SEATING, NATURE, AND SHADE!**"

Need **USABLE SPACE** for employees working in MSB

"I would like to see **COLOR**"

"The new Plaza must have a **BETTER QUALITY OF LIFE** environment and be **INVITING TO USERS**, including families and City employees."

"It should be as **INVITING AND ACCESSIBLE** as possible for all Philadelphians...."

The design addresses these priorities in the following ways:

- adds shade trees
- adds plant beds
- locates seating near plants

- creates seating near building
- makes space for outside meetings and lunch
- provides variety of seat types and locations

- adds new lighting throughout
- provides space for public art
- improves views from sidewalk to plaza

- sloped walk or ramp from JFK Boulevard sidewalk
- sloped walk to MSB entry
- better circulation and wayfinding through site

**ENGAGEMENT FEEDBACK**

## ANALYZE THE SITE

Engage users and tenants, and study site to understand what could be improved

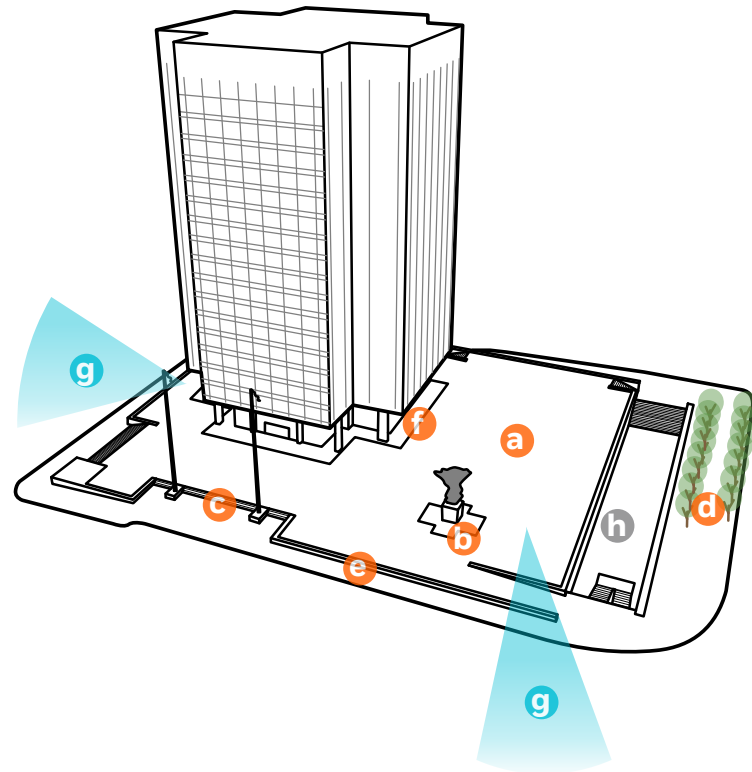

- a** Underutilized and undefined plaza
- b** *Government of the People* sculpture
- c** Non-accessible arrival sequence
- d** Limited shade trees
- e** Imposing and uninviting perimeter walls
- f** Perimeter of MSB uninviting
- g** Views to City Hall and Love Park
- h** Sunken courtyard (not in scope)

## PROGRAM THE PLAZA

Create accessible connections, define inhabitable spaces, and respond and relate to MSB design

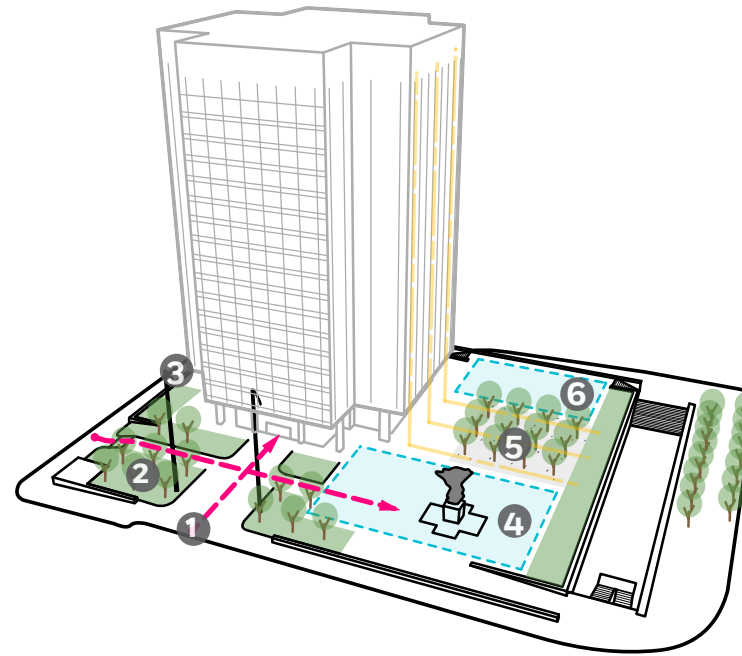

- 1** New access ramp / sloped walk
- 2** Arrival grove
- 3** West terrace
- 4** Large plaza (1000 people)
- 5** Seating bosque
- 6** Small plaza

## ORIENT TOWARDS CITY HALL

Rotate plaza to connect to context, improve circulation, provide more green space, and respond to public art

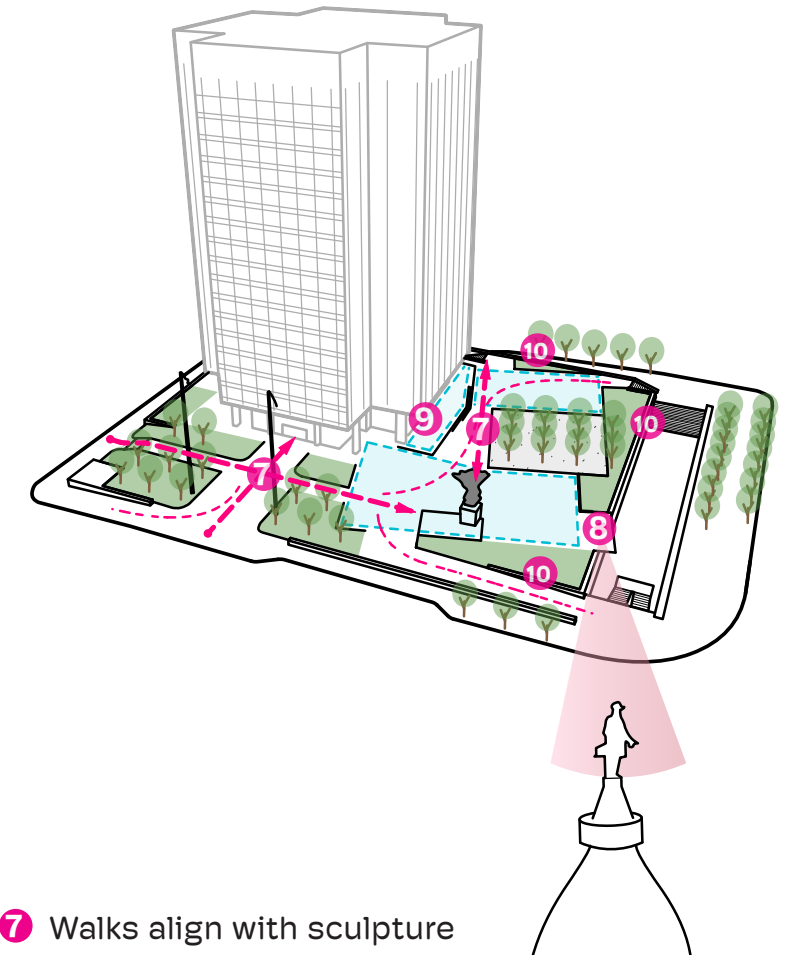

- 7** Walks align with sculpture
- 8** Overlook with view to William Penn and City Hall
- 9** More accessible, occupiable space at MSB perimeter
- 10** Additional green space

## CONCEPT DEVELOPMENT



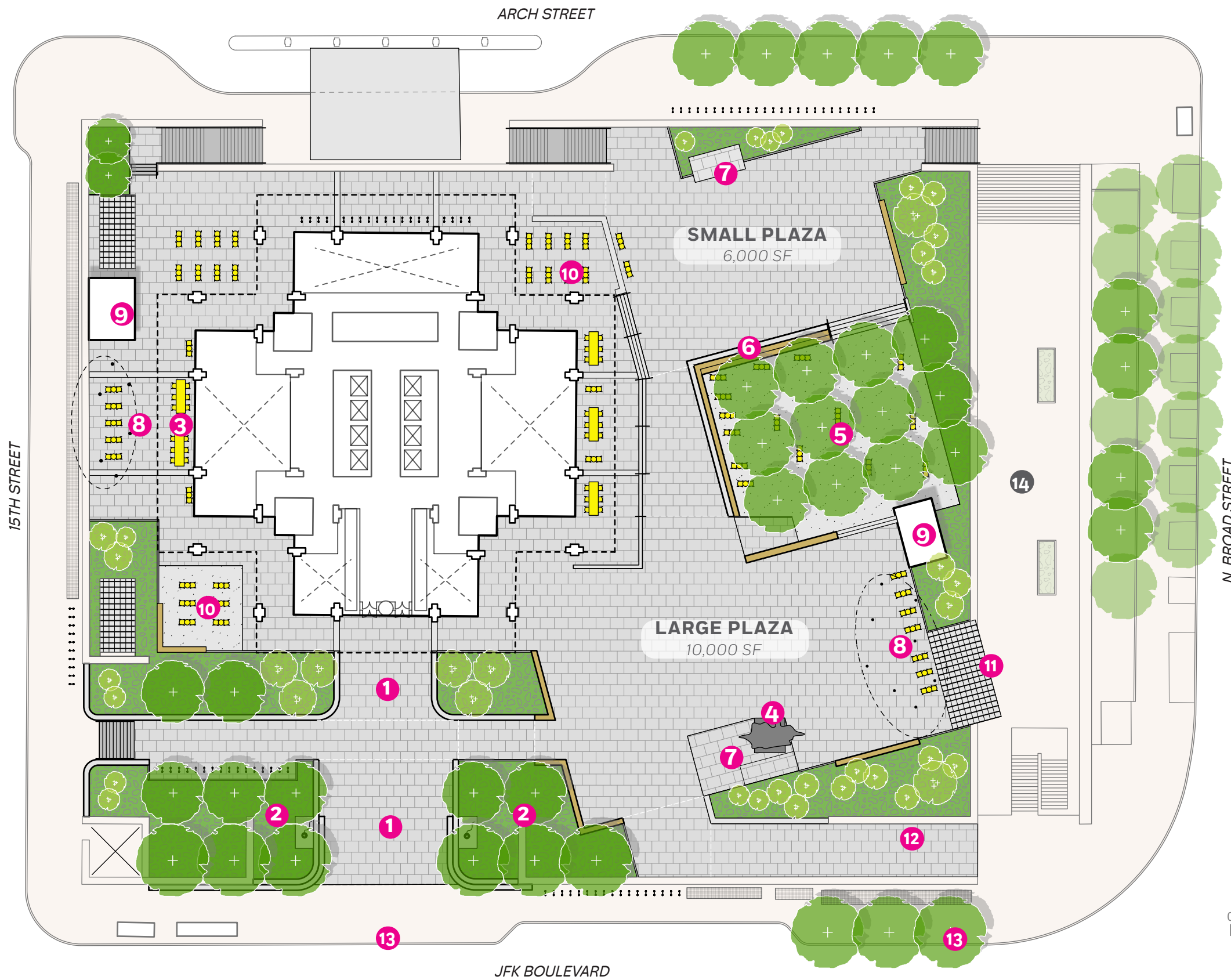

### SPACES + ELEMENTS

- 1 New access ramp / sloped walk
- 2 Arrival grove
- 3 West terrace
- 4 *Government of the People*
- 5 Seating bosque, stone fines
- 6 Terraced social seating
- 7 Stage / platform
- 8 Canopy / shade structure
- 9 Kiosk
- 10 Seating terrace at MSB perimeter
- 11 Observation overlook
- 12 Existing access ramp
- 13 Proposed curb bump out
- 14 Sunken plaza (not in scope)

### PROPOSED PLAN

THOMAS PAINE PLAZA  
Plaza Improvement Project

Department of  
Public Property

Ground Reconsidered  
Landscape Architecture



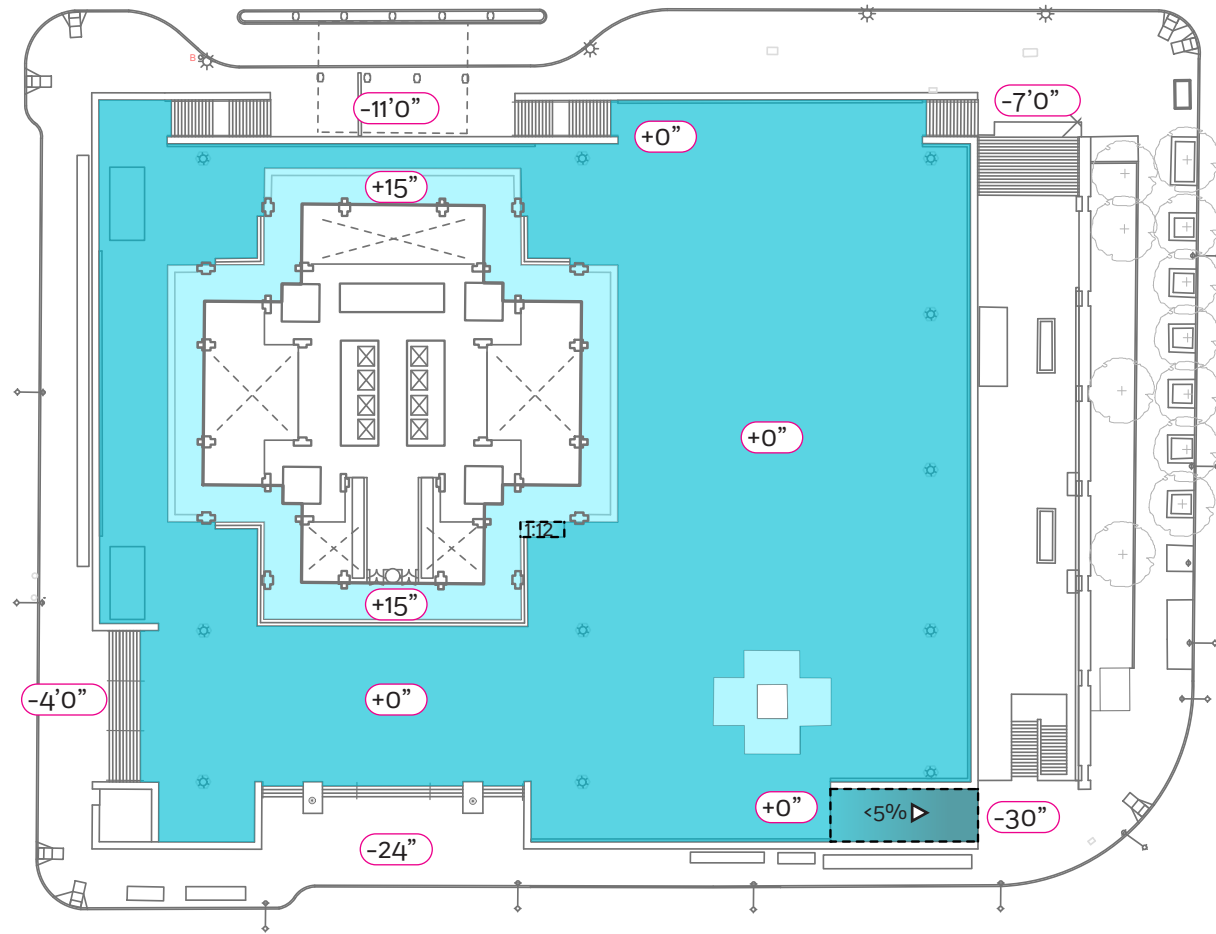

EXISTING ELEVATIONS

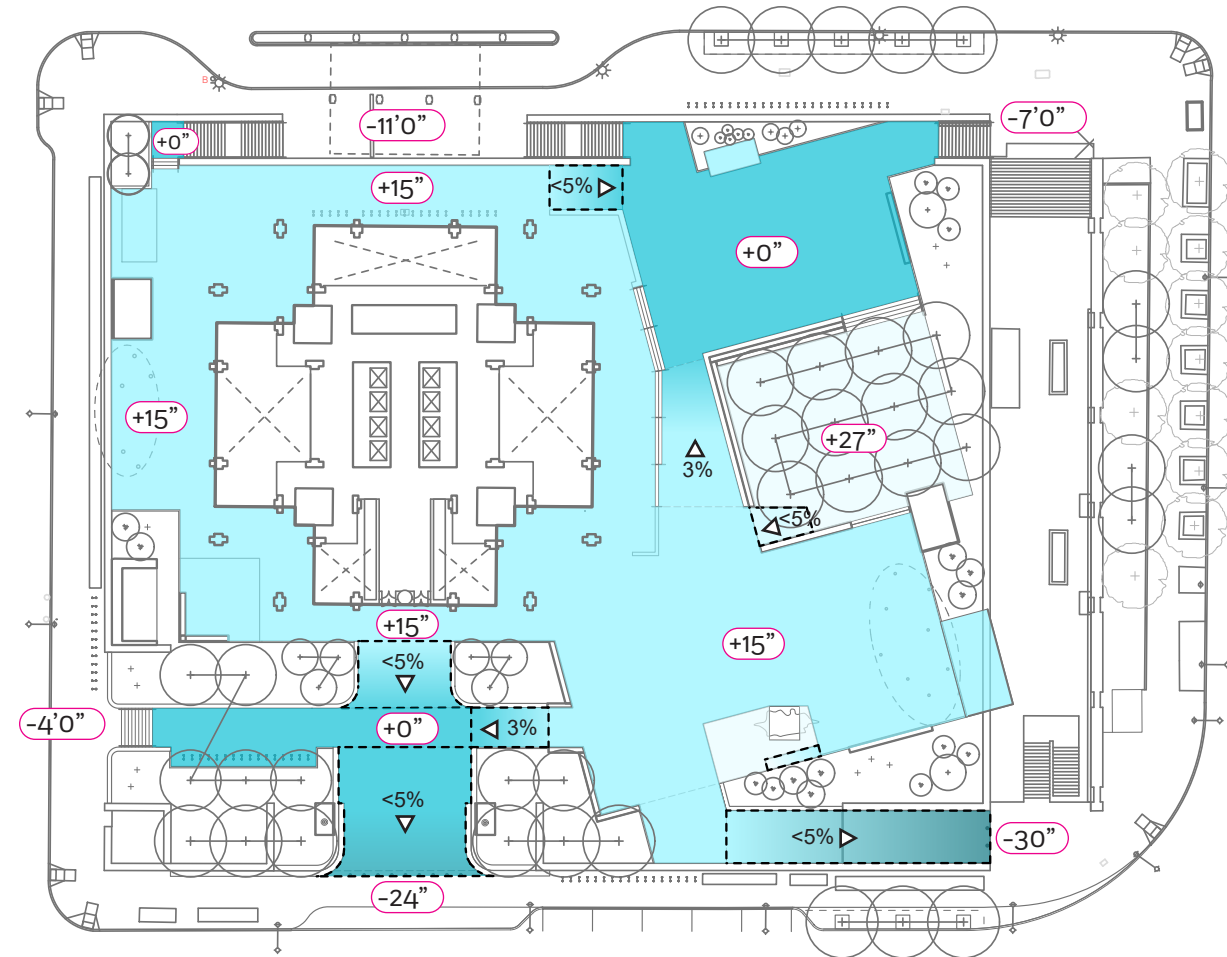

PROPOSED ELEVATIONS

**ELEVATION CHANGES + ACCESSIBILITY**

EXISTING

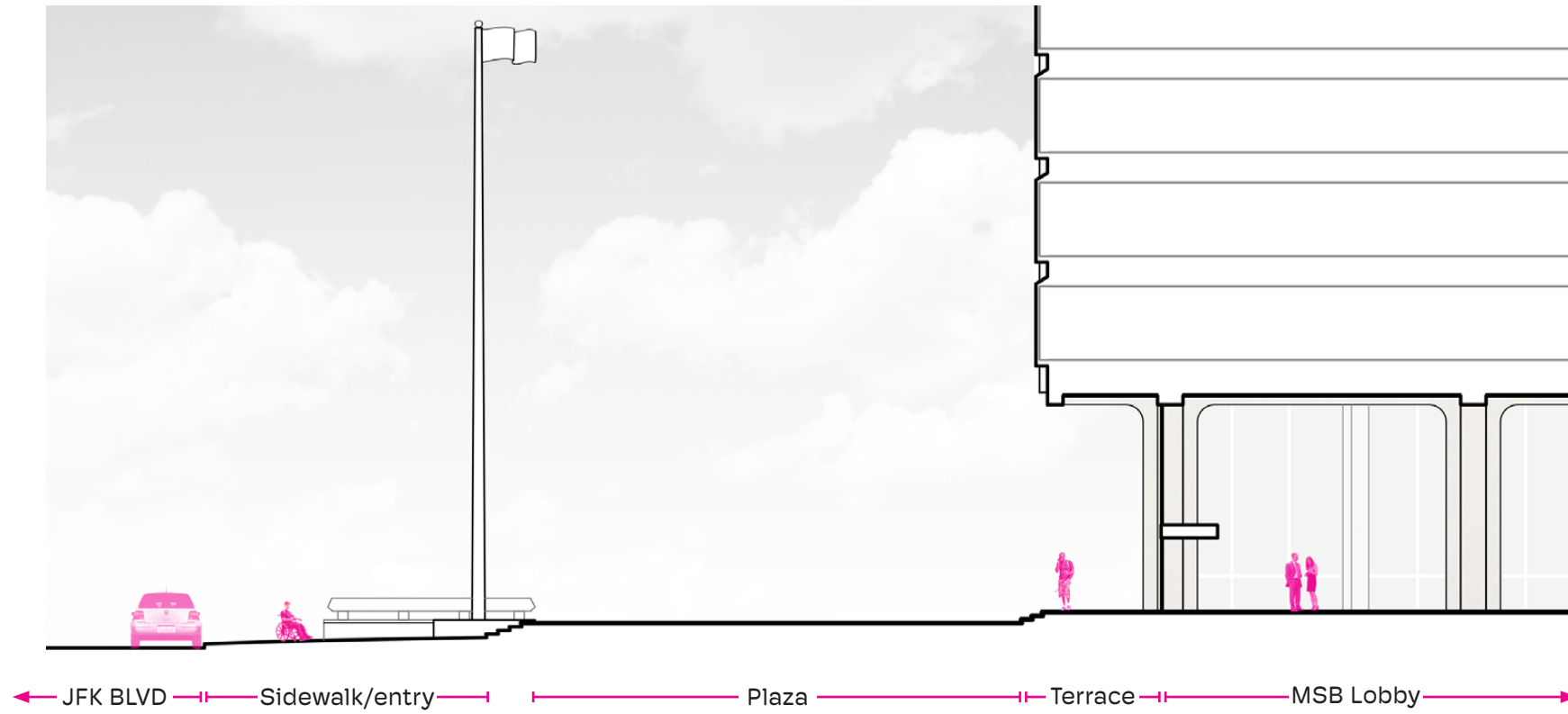

PROPOSED

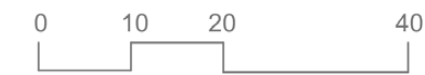
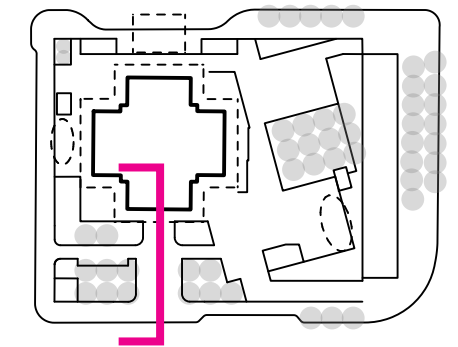

**SITE SECTIONS - JFK BOULEVARD ENTRY**



EXISTING



PROPOSED

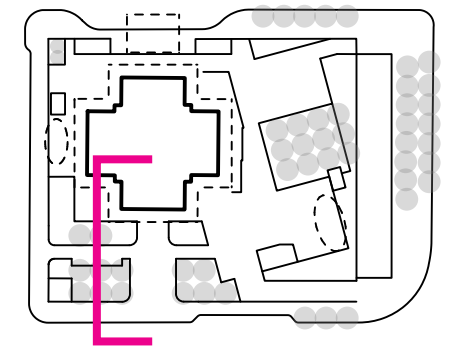
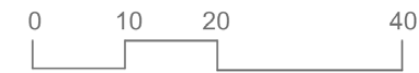
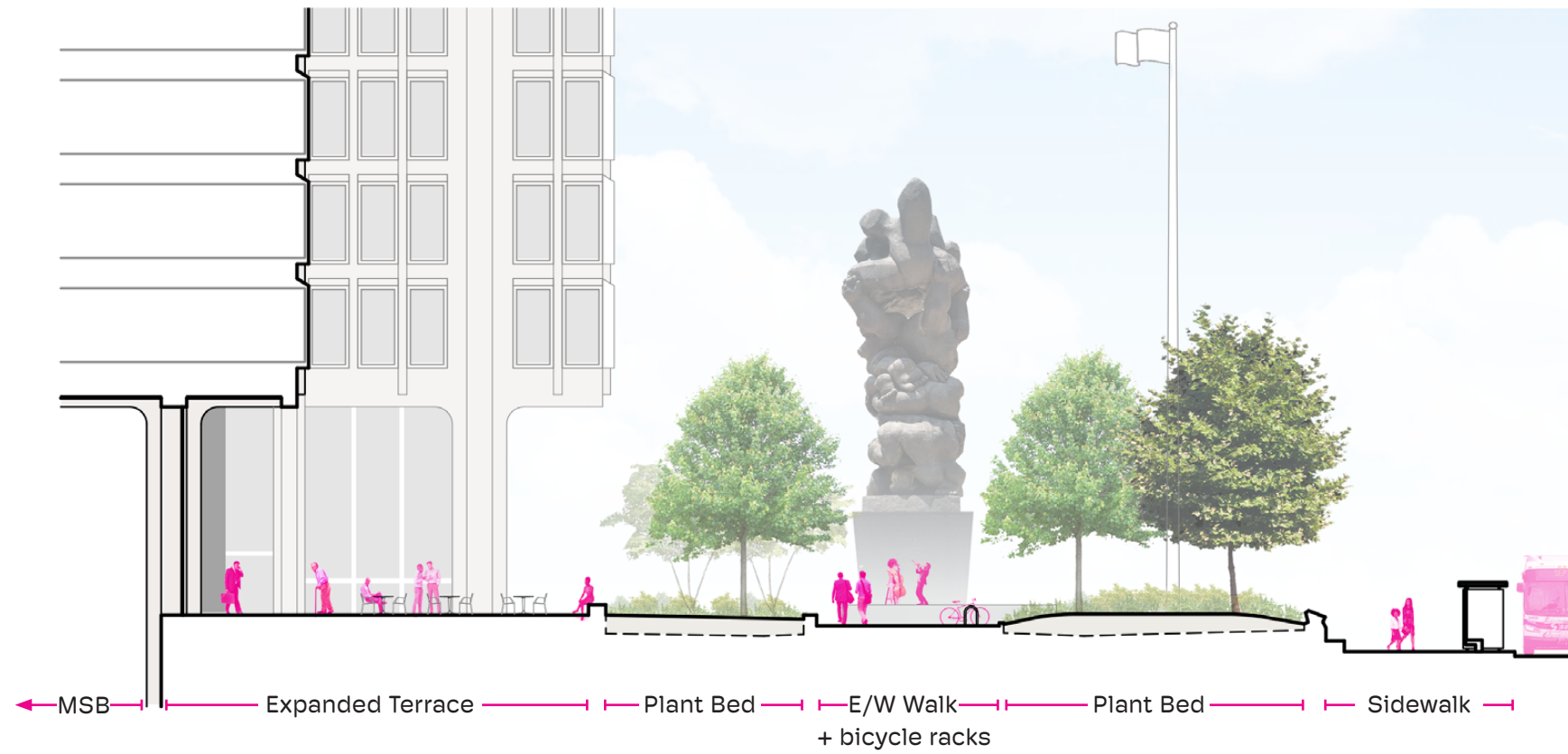

**SITE SECTIONS - PATH FROM 15TH STREET**

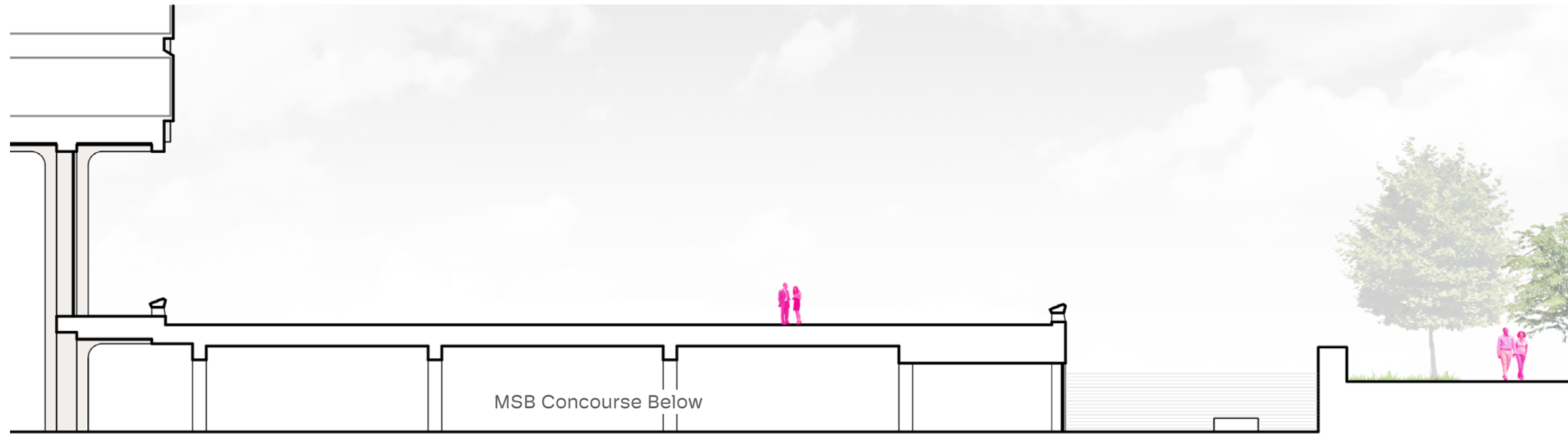

EXISTING

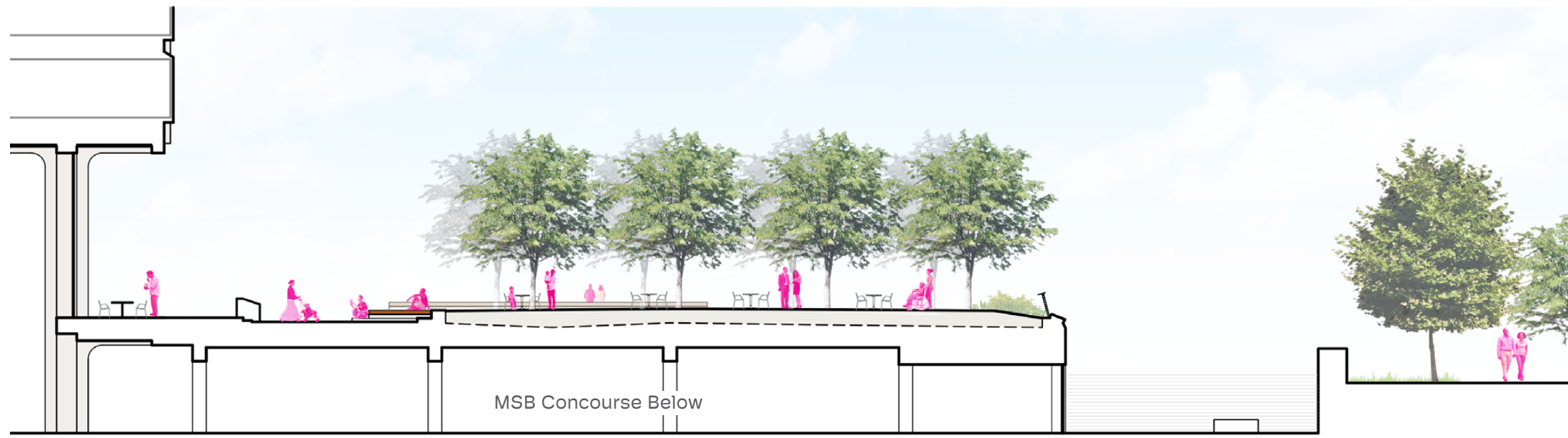

PROPOSED

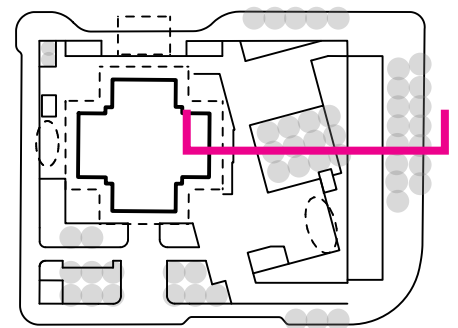

**SITE SECTIONS - THROUGH EAST PLAZA**



SEAT WALL



ORNAMENTAL TREES



ACCESSIBLE WALK



ARRIVAL GROVE



Site arrival at JFK Boulevard

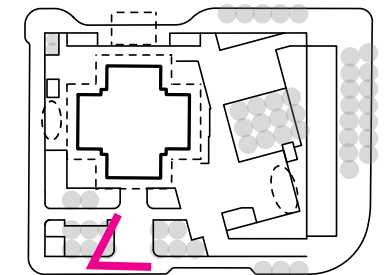

### SITE PERSPECTIVES

THOMAS PAINE PLAZA  
Plaza Improvement Project





SHADE CANOPY



CODE-COMPLIANT AND VISUALLY-OPEN GUARDRAIL

PLANT BEDS



SEATING UNDER SHADE TREES



Site arrival at 15th Street

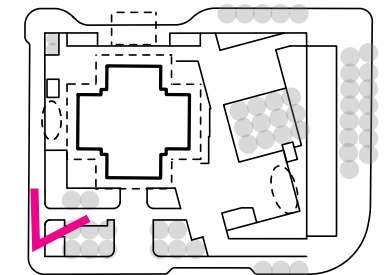

### SITE PERSPECTIVES

THOMAS PAINE PLAZA  
Plaza Improvement Project





PLANT BED



SHADE TREES



SEAT WALL



BICYCLE PARKING



West Stairs + Path

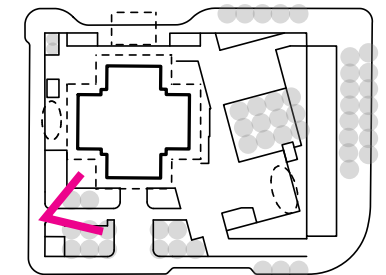

### SITE PERSPECTIVES

THOMAS PAINE PLAZA  
Plaza Improvement Project





PLANT BED



SHADE CANOPY



SEATING UNDER CANOPY



FLEXIBLE SEATING



West Terrace

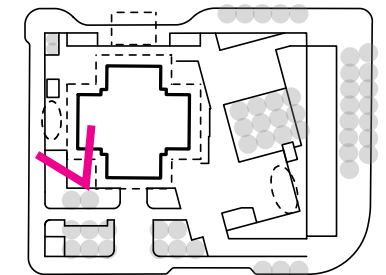

**SITE PERSPECTIVES**

THOMAS PAINE PLAZA  
Plaza Improvement Project





PLANT BED



SHADE CANOPY



LOVE STATUE

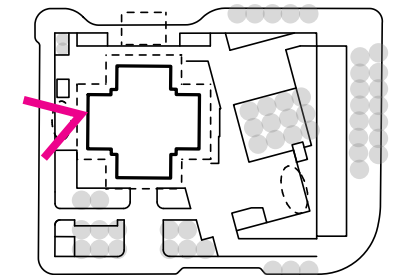

**SITE PERSPECTIVES**

THOMAS PAINE PLAZA  
Plaza Improvement Project





BOSQUE



WOOD BENCHES



SPACE FOR 500 PEOPLE



SEATING UNDER EAVES



PLATFORM / STAGE



Small Plaza

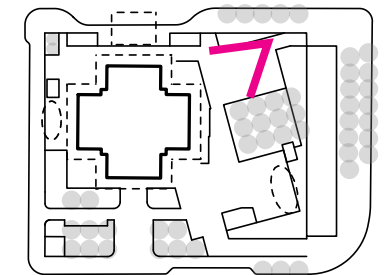

**SITE PERSPECTIVES**

THOMAS PAINE PLAZA  
Plaza Improvement Project





BOSQUE



NEW LIGHTING



SLOPED WALK



WOOD BENCHES



GOVERNMENT OF THE PEOPLE

STREET TREES



View to Large Plaza

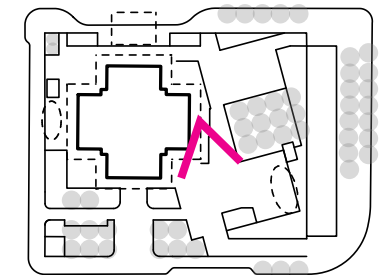

**SITE PERSPECTIVES**

THOMAS PAINE PLAZA  
Plaza Improvement Project





SHADE CANOPY



GOVERNMENT OF THE PEOPLE



PLATFORM / STAGE



SPACE FOR 1000 PEOPLE



WOOD BENCHES

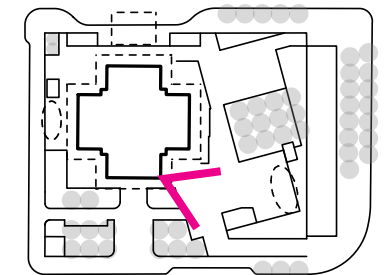
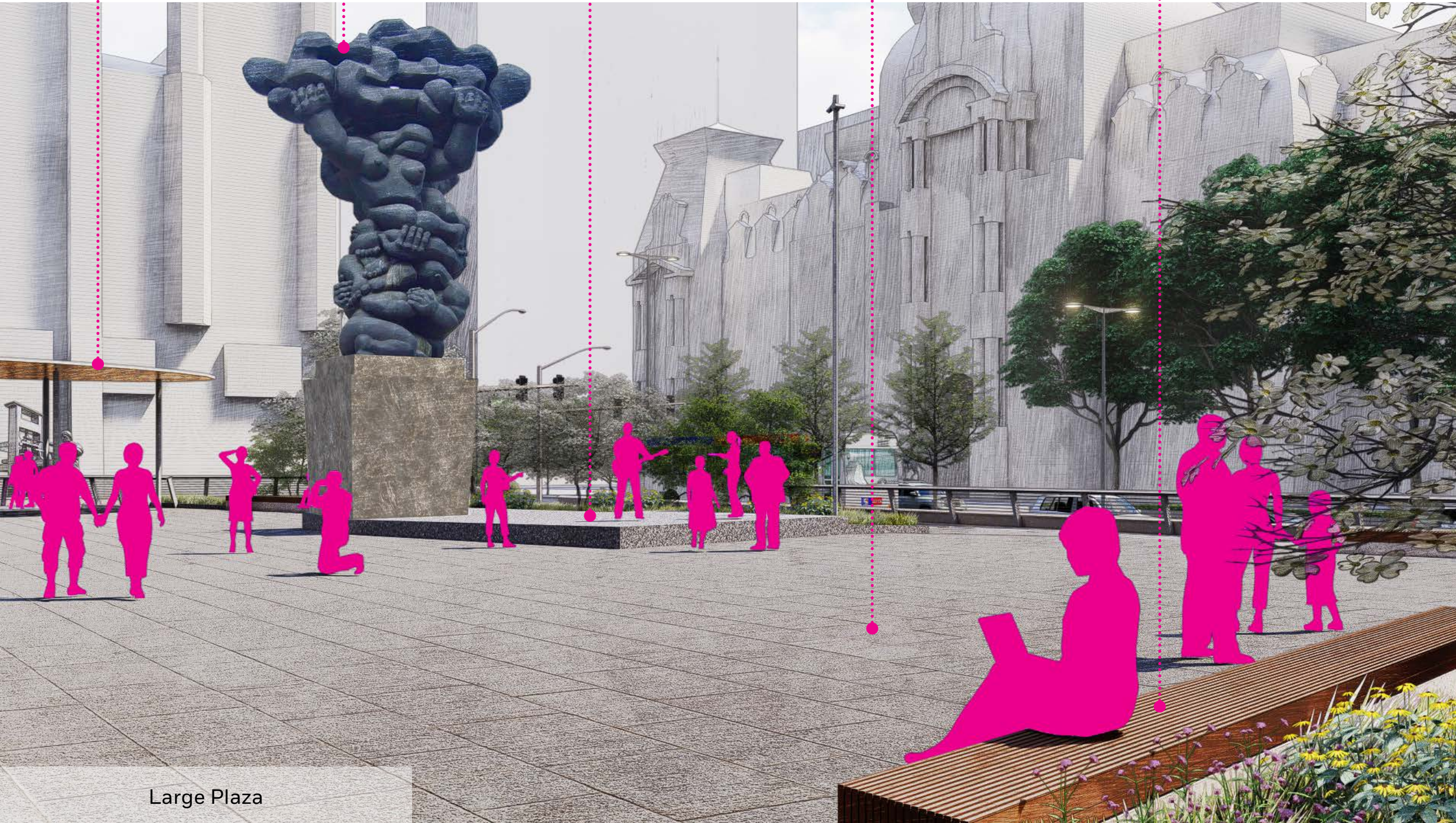

Large Plaza

SITE PERSPECTIVES

THOMAS PAINE PLAZA  
Plaza Improvement Project





WOOD BENCHES



BOSQUE



SHADE CANOPY



PROPOSED KIOSK

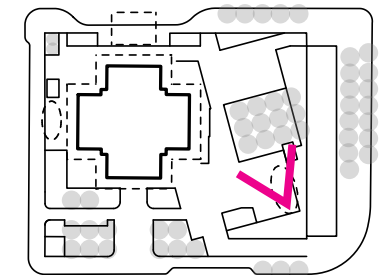

Canopy at Large Plaza

**SITE PERSPECTIVES**

THOMAS PAINE PLAZA  
Plaza Improvement Project







East Kiosk & Canopy



West Kiosk & Canopy

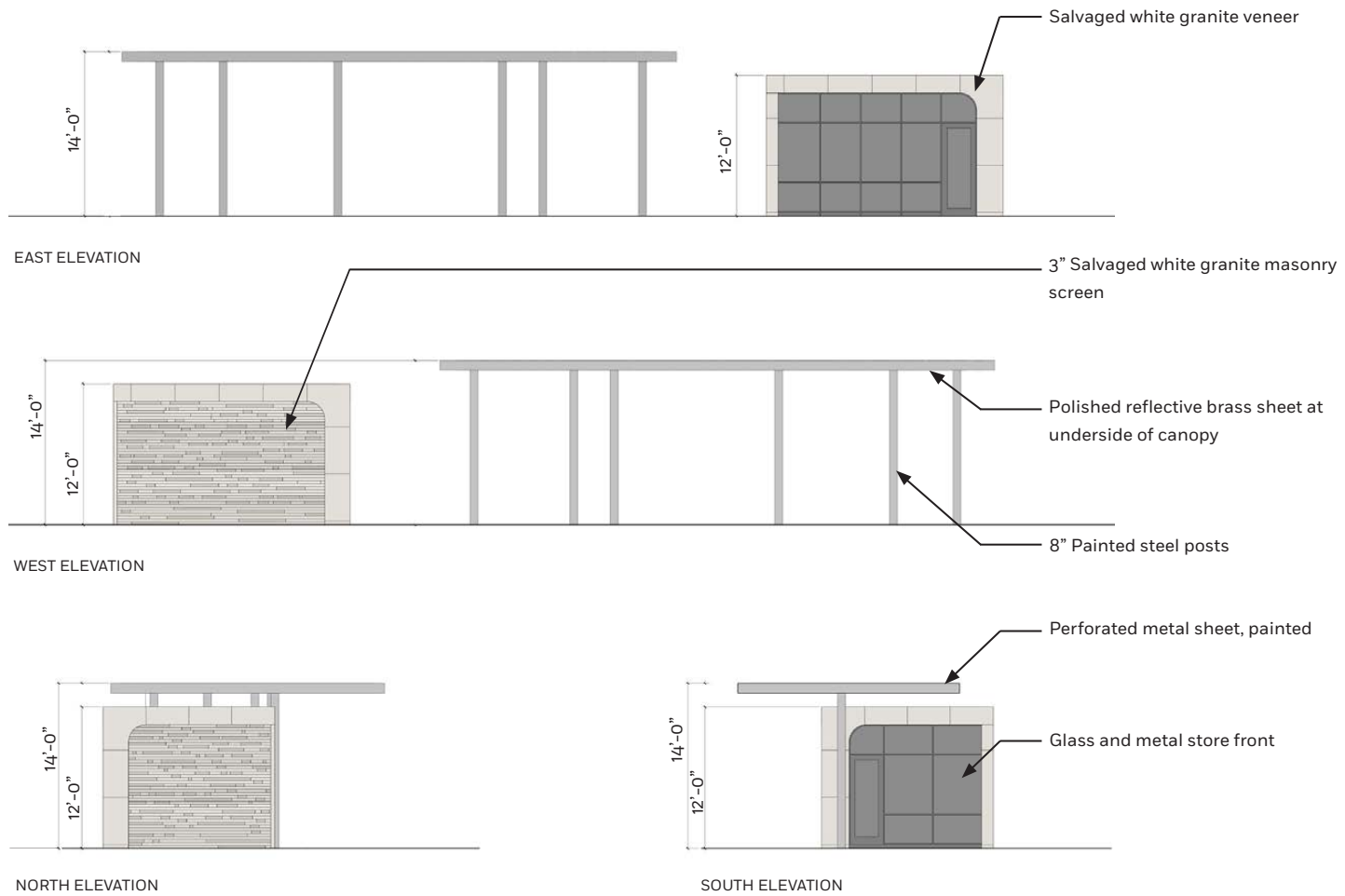

WEST CANOPY & KIOSK



MSB EXTERIOR



VIEW FROM MSB LOWER LEVEL LOOKING OUT

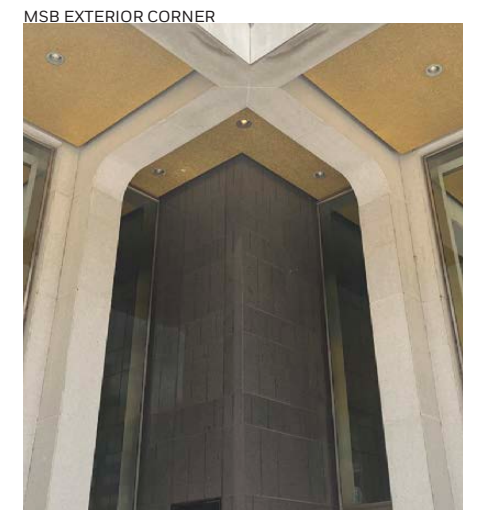

MSB EXTERIOR CORNER



MIRRORED CANOPY PRECEDENT

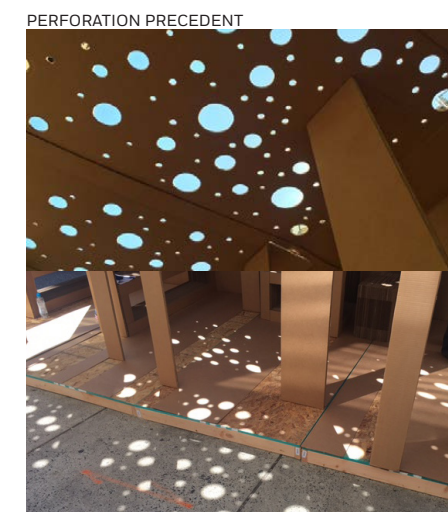

PERFORATION PRECEDENT

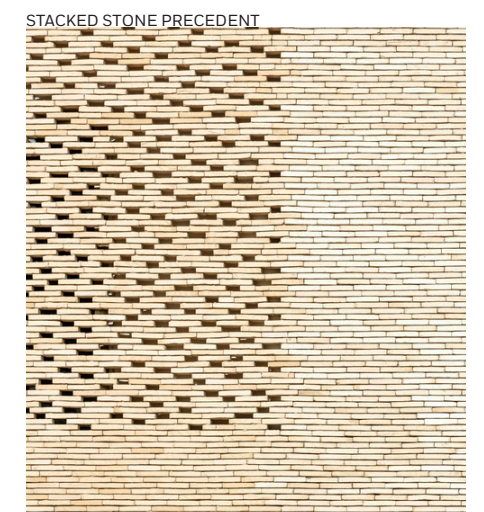

STACKED STONE PRECEDENT

## KIOSKS + CANOPIES





- 1** Type A20  
Retrofit Downlight
- 2** Type D1  
Railing Light
- 3** Type M1  
Bench Light
- 4** Type M2  
Ingrade Tree Uplight
- 5** Type M4  
Stringlight Accent
- 6** Type P2  
Post-top Pole Light
- 7** Type P1  
Pole Mounted Flood Light
- 8** Type M2  
In-grade Accent
- 9** Type P3  
Globe Post-top Pole Light
- 10** Type D3  
Pole Mounted Flag Accent
- 11** Type D2  
"Starry" Downlight Arrays  
At Structures
- 12** Type M2A  
Ingrade Column Uplight
- 13** RGBW Lighting  
Multiheaded Poles,  
Underbench, Tree Uplights
- 14** Type D5  
Wall Mounted Flood Light

## EXTERIOR LIGHTING CONCEPTS





13

**RGBW Lighting**

Color lighting can be programmed for activities and events at plaza

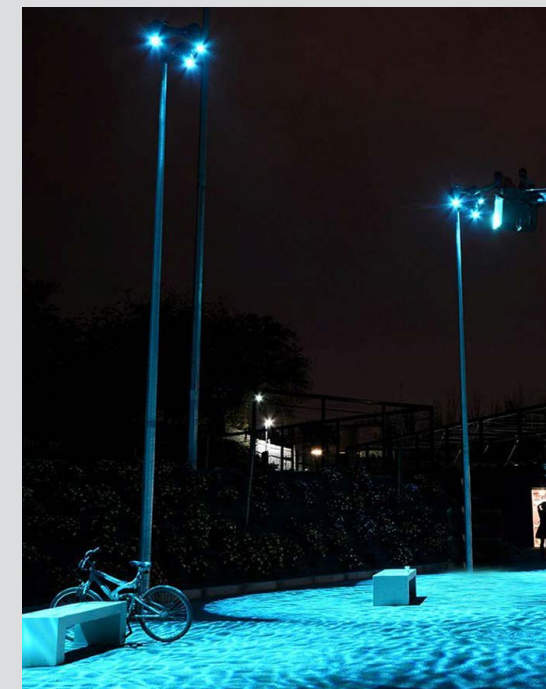

**EXTERIOR LIGHTING - COLOR PROGRAMMING**



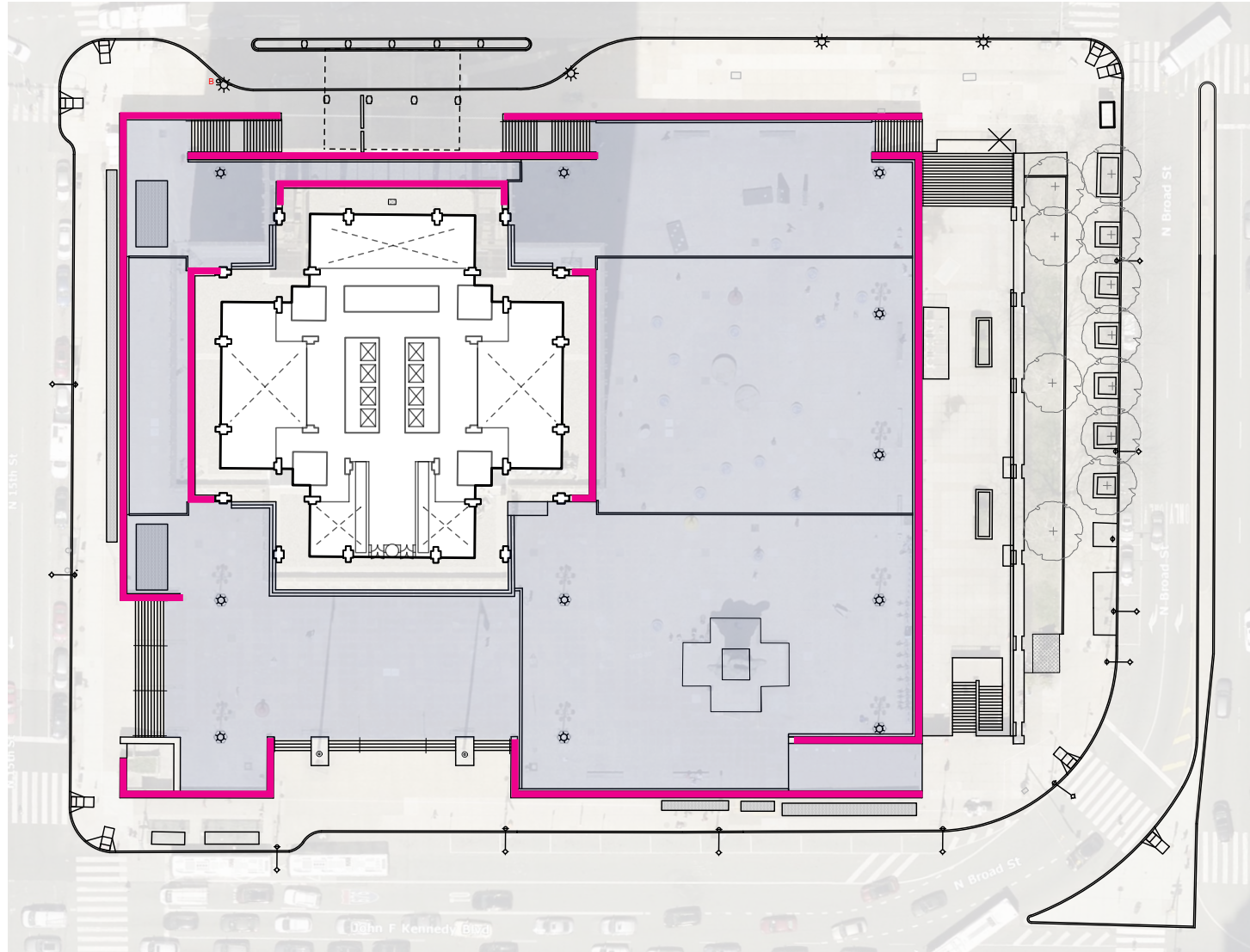

EXISTING SITE PLAN

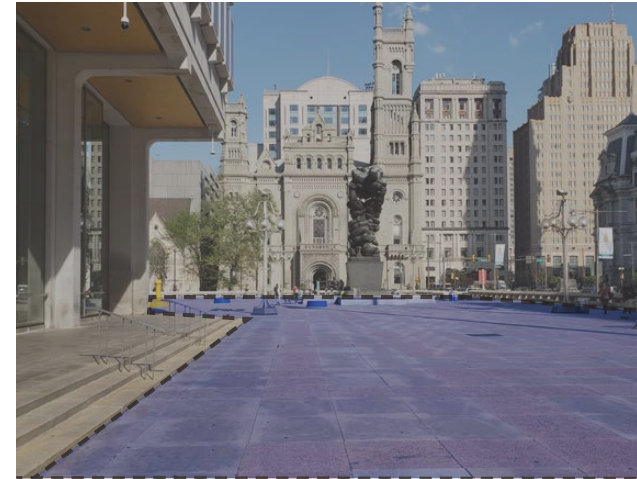

GRANITE PAVERS

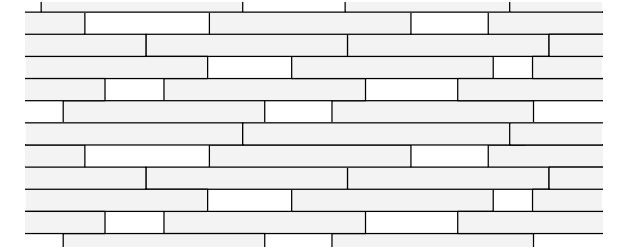

Structures on site utilize stacked granite paving strips as wall cladding.



GRANITE RAILINGS

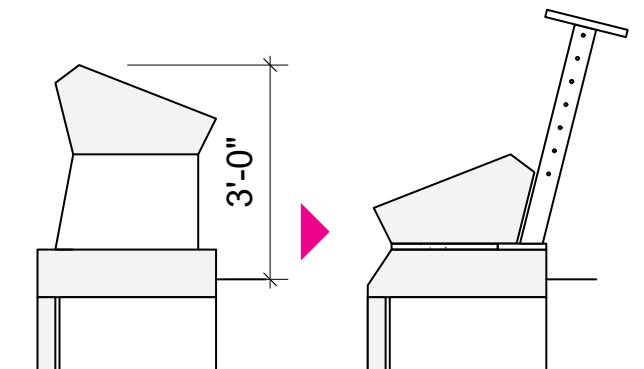

At site perimeter, reset railing as coping with new code-compliant guardrail.

**MATERIAL REUSE**



WOOD SEAT WALL



BICYCLE RACKS



Proposed Color: Black

GRANITE PAVERS

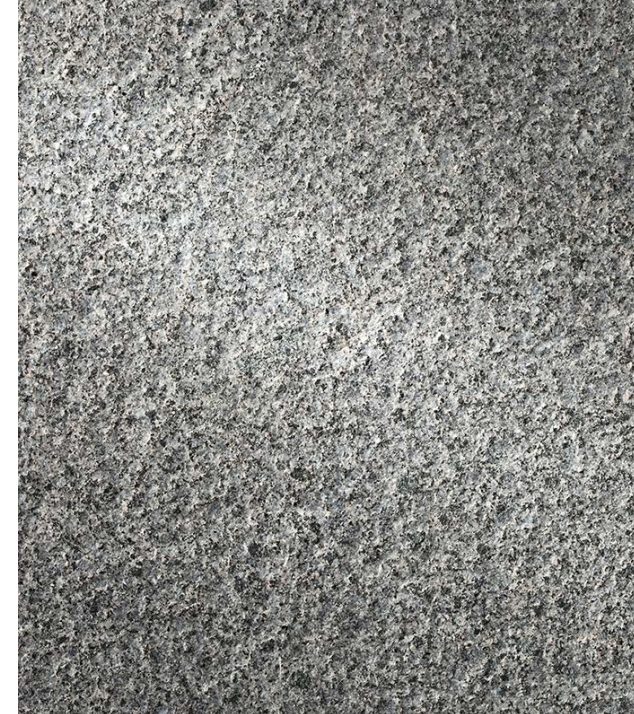

GRANITE SEAT WALL



TRASH RECEPTACLE



Proposed Color: To be determined

STONE FINES



METAL GRATING



**MATERIALS + FIXED FURNISHINGS**





**BLOCQ TABLE WITH BENCHES, MMCITE**  
 Proposed Colors: To be determined, wood to match fixed benches

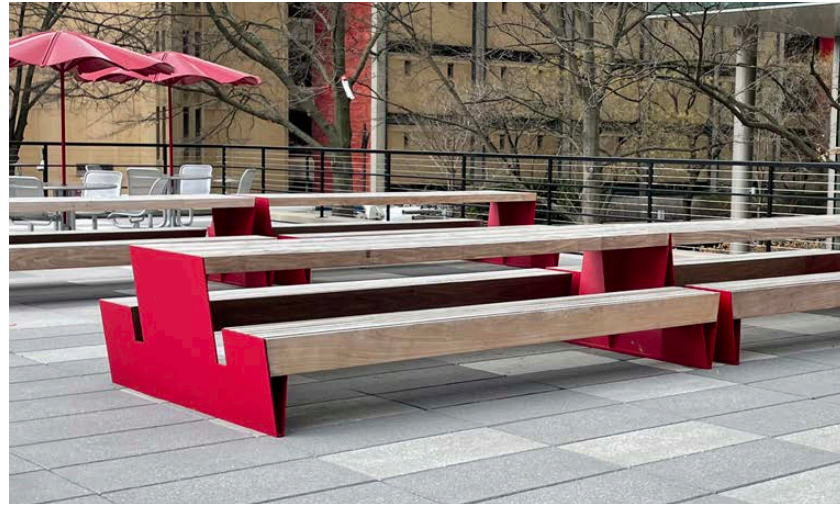

**BLOCQ TABLE WITH BENCHES, MMCITE**  
 Proposed Colors: To be determined, wood to match fixed benches



**BLOCQ TABLE WITH BENCHES, MMCITE**  
 Proposed Colors: To be determined



**BLOCQ TABLE WITH BENCHES, MMCITE**  
 Proposed Colors: To be determined

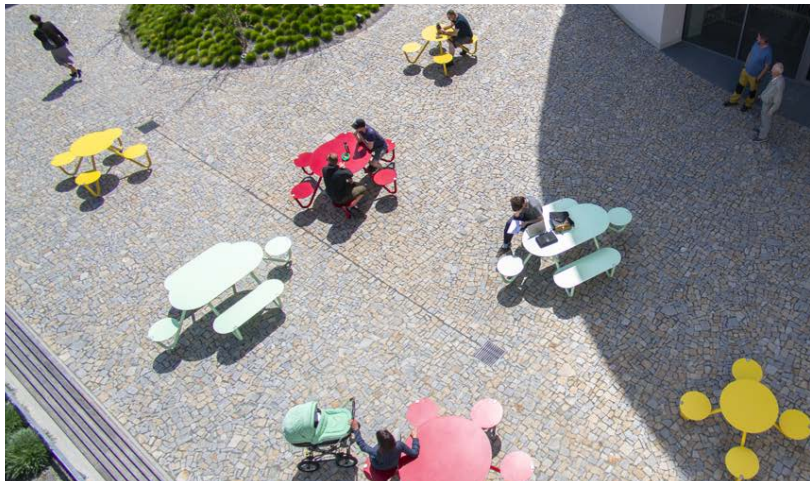

**ORBIT PICNIC-STYLE TABLES, MMCITE**  
 Proposed Colors: To be determined

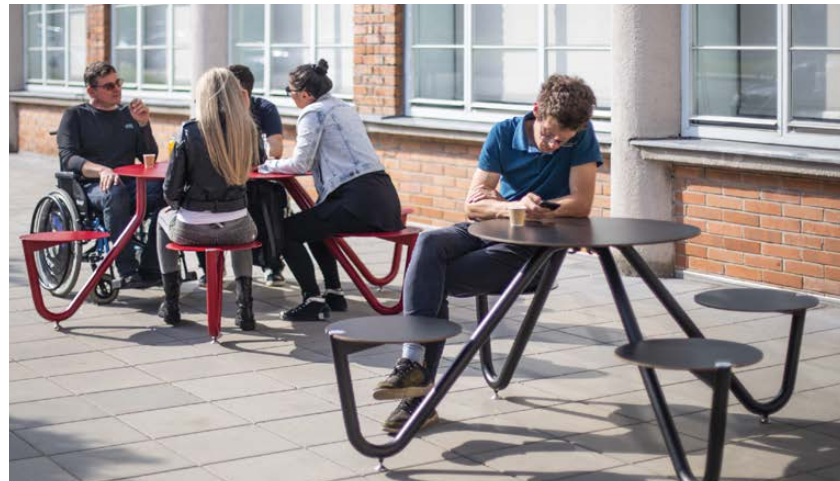

**ORBIT PICNIC-STYLE TABLES, MMCITE**  
 Proposed Colors: To be determined



**BRAVO BISTRO TABLES AND CHAIRS, LANDSCAPE FORMS**  
 Proposed Colors: To be determined

**POTENTIAL FURNISHINGS**



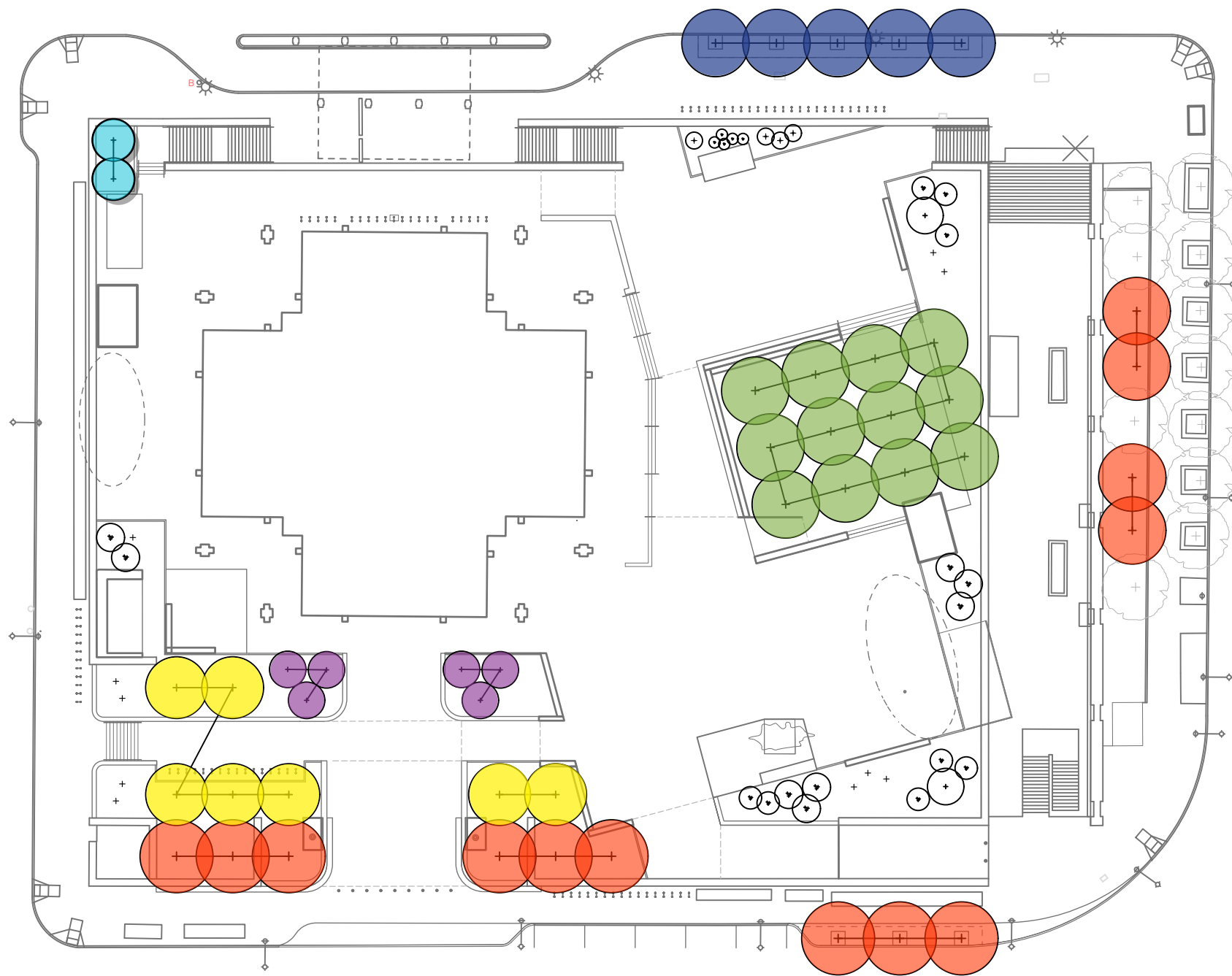

**BOSQUE**



'Shademaster' Honey Locust  
*Gleditsia triacanthos inermis*  
'Shademaster'

**ALLEE**



'October Glory' Red Maple  
*Acer rubrum* 'October Glory'

**STREET TREE**



'Morton Circle' London Plane Tree  
*Platanus x acerifolia* 'Morton Circle'

**MAIN ENTRANCE**



'Cherokee Princess' Dogwood  
*Cornus florida* 'Cherokee Princess'

**NW CORNER PLANTER**

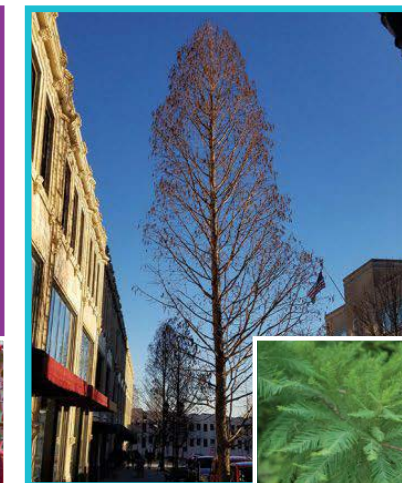

Shawnee Brave Baldcypress  
*Taxodium distichum* 'Mickelson'

**STREET TREE**



Swamp White Oak  
*Quercus bicolor*

**PLANTING PLAN - TREES**



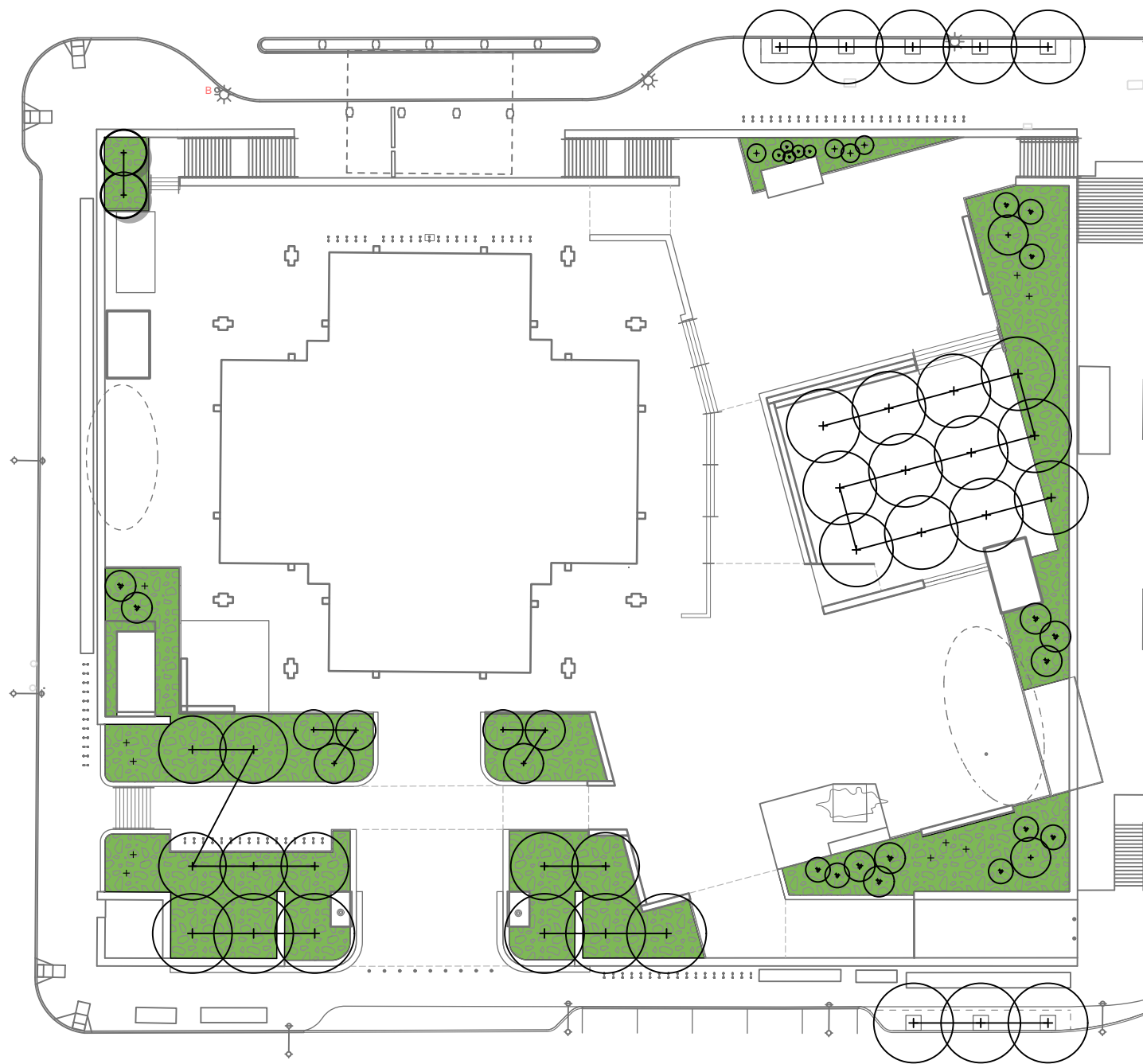

**GRASS MATRIX**



**Blue Grama Grass**  
*Bouteloua gracilis*



**Tufted Hair Grass**  
*Deschampsia cespitosa*



**Pink Muhly Grass**  
*Muhlenbergia capillaris*



**Wood's Sedge**  
*Carex woodii*

**SHRUB ACCENTS**



**American Cranberrybush**  
*Viburnum trilobum*



**Witch-hazel**  
*Hamamelis virginiana*



**'Ruby Slippers' Oakleaf Hydrangea**  
*Hydrangea quercifolia "Ruby Slippers"*

**PERENNIAL ACCENTS**



**Blue Mistflower**  
*Conoclinium coelestinum*



**Showy Coneflower**  
*Rudbeckia fulgida var. fulgida*



**Argentinian Vervane**  
*Verbena bonariensis*



**Threadleaf Blue Star**  
*Amsonia hubrichtii*



**Foxglove Beardtongue**  
*Penstemon digitalis*



**Purple Cone Flower**  
*Echinacea purpurea*

**PLANTING PLAN - PLANT BEDS**





View from City Hall / Aerial

## SITE PERSPECTIVE

THOMAS PAINE PLAZA  
Plaza Improvement Project





# SCHEDULE

**Design and Documentation: Present through January 2024**

**Bidding + Contractor Selection: February through May 2024**

**Construction Commences: May 2024**

# BUDGET

**Estimated to be \$20,000,000**

## BUDGET AND SCHEDULE



June 28, 2023

Beige Berryman  
The Philadelphia Art Commission  
One Parkway, 1515 Arch Street, 13<sup>th</sup> Floor  
Philadelphia, PA 19102

Re: Letter of Intent for Percent for Art at Thomas Paine Plaza

Dear Beige:

The Office of Arts, Culture and the Creative Economy (OACCE) would like to inform the Philadelphia Art Commission of our intent to provide a Percent for Art opportunity at Thomas Paine Plaza in collaboration with the Department of Public Property (DPP). Paine Plaza is located at the Municipal Services Building (MSB) and will be undergoing significant improvements to transform it into a vibrant civic space. Due to the City's current Percent for Art projects that are underway, the timeline for this future Percent for Art project is still being determined with OACCE and DPP. Below is an overview of our anticipated understanding and approach for this future public art project:

- The Thomas Paine Plaza Percent for Art opportunity will create a beautiful and enduring work of public art that is permanent, site-specific, and reflects the culture, values and diversity of the city of Philadelphia. The Art budget will be at least 1% of the total project budget in keeping with the City's Percent for Art guidelines.
- A Thomas Paine Plaza Percent for Art Committee will be formed to advise the selection of the artist and the art proposal and will include representatives from: the Paine Plaza Design team; public art artists; staff members and public users of the Municipal Services Building; representatives from elected City official offices, representatives from other relevant City offices, Department of Public Property, and OACCE.
- The Artist will be selected through a two-part competition, consisting of a Call for Artist Phase 1 where artists submit qualifications, and a subsequent Phase 2 where 3 to 4 semi-finalists who have been selected by the Committee will move forward with providing proposals. Public involvement will be a critical component, and artist teams will be encouraged to align their proposal with feedback and input from members of the public. Public engagement will occur in virtual and/or in-person meetings with the public, and through online public surveys. The Committee will review all proposals and the public's feedback to select one winning finalist artist or artist team.
- OACCE will provide oversight for the Percent for Art process from concept to installation and will work with the artist and project team to ensure the technical details for the artwork are coordinated with the site. Once the Finalist artist is selected and the artwork has been developed, OACCE will initiate a separate review process with the Philadelphia Art Commission for approving the artwork.

We look forward to working with the Paine Plaza project team and all stakeholders to realize a beautiful, site specific public artwork that will be a long lasting contribution to Thomas Paine Plaza and will enhance the City's renowned collection of public art. Should you require any additional information please do not hesitate to call me at 215.686.4596.

Sincerely,



Marguerite Anglin, RA, NOMA  
Public Art Director  
Office of Arts, Culture and the Creative Economy